

VERDERAIR VA-2E Pumps, Industrial Models

813-0525B

EN

Electric-operated diaphragm (EODD) pumps with an integral electric drive for fluid transfer applications. Not for use with hygienic (sanitary) applications. Not for use with gasoline. For professional use only.



Important Safety Instructions

Read all warnings and instructions in this manual and related manuals before using the equipment. Save these instructions.

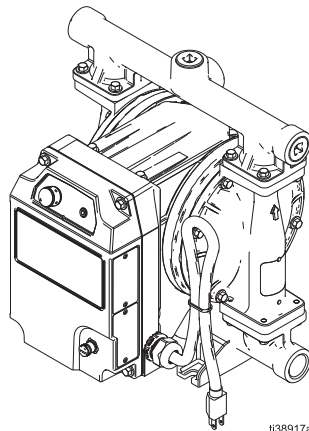

ti38917a

VA-2E25 Model

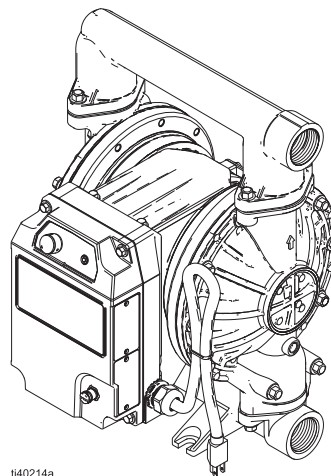

ti40214a

VA-2E40 Model

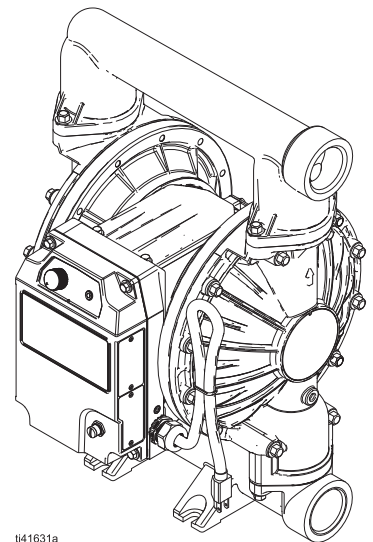

ti41631a

VA-2E50 Model



Contents







Related Manuals	2	Maintenance	28
Warnings	3	Lubricate the Equipment	28
Configuration Matrix	7	Flush the Equipment	28
Approvals	9	Store the Equipment	29
Component Identification	10	Troubleshooting	30
Typical Installation	11	Repair	32
General Information	11	Prepare Equipment for Repair	32
Typical Installation for Models in Ordinary		Repair the Check Valves	33
Locations	11	Repair the Standard Diaphragms	34
Typical Installation for Models in Explosive		Repair the Overmolded Diaphragms	36
Atmospheres or Hazardous (Classified)		Recycling and Disposal	38
Locations	12	End of Equipment Life	38
Installation	13	Torque Fasteners	39
Mount the Pump	13	Torque Instructions	39
Connect Fluid Lines	13	Torque Sequence	39
Install Accessories	14	Performance Charts	42
Grounding	15	Performance Chart for VA-2E25 Models	42
Before First Use	16	Performance Chart for VA-2E40 Models	43
Electrical Connections and Wiring	17	Performance Chart for VA-2E50 Models	43
Required Power and Plugs	17	Dimensions	44
Wire Power Cables	18	Dimensions for VA-2E25 Models	44
Requirements for Cables and Conduits	19	Dimensions for VA-2E40 Models	46
Adapters for Plugs and Cables	19	Dimensions for VA-2E50 Models	48
I/O Pin Connection	20	Technical Specifications	50
Operation	22	Fluid Temperature Range	50
Pressure Relief Procedure	22	Technical Specifications for VA-2E25 Models ..	51
Before Each Use	22	Technical Specifications for VA-2E40 Models ..	52
Start the Equipment	22	Technical Specifications for VA-2E50 Models ..	53
Shut Down the Equipment	24	California Proposition 65	53
LED Indicator	25	Customer Services/Guarantee	55
LED Indicator Overview	25		
Troubleshoot LED Indicator Event Errors	26		

Related Manuals

English Manual Number	Description	Reference
813-0526	VERDERAIR VA-2E Electric Motor, Repair-Parts	Motor Manual
813-2156	VERDERAIR VA-2E Pumps, Parts, Industrial Models	Parts Manual
813-0522	VERDERAIR VA-2E Leak Sensor	Kit Instructions
813-0523	VERDERAIR VA-2E I/O Cable Kit (Hazardous Locations)	Kit Instructions

Warnings

The following warnings are for the setup, use, grounding, maintenance, and repair of this equipment. The exclamation point symbol alerts you to a general warning and the hazard symbols refer to procedure-specific risks. When these symbols appear in the body of this manual or on warning labels, refer back to these Warnings. Product-specific hazard symbols and warnings not covered in this section may appear throughout the body of this manual where applicable.

 WARNING	
    	<p>FIRE AND EXPLOSION HAZARD</p> <p>Flammable fumes, such as solvent and paint fumes, in work area can ignite or explode. Paint or solvent flowing through the equipment can cause static sparking. To help prevent fire and explosion:</p> <ul style="list-style-type: none"> • Use equipment only in well-ventilated area. • Eliminate all ignition sources; such as pilot lights, cigarettes, portable electric lamps, and plastic drop cloths (potential static sparking). • Ground all equipment in the work area. See Grounding instructions. • Keep work area free of debris, including solvent, rags and gasoline. • Do not plug or unplug power cords, or turn power or light switches on or off when flammable fumes are present. • Use only conductive grounded fluid lines. • Stop operation immediately if static sparking occurs or you feel a shock. Do not use equipment until you identify and correct the problem. • Keep a working fire extinguisher in the work area. <p>Static charge may build up on plastic parts during cleaning and could discharge and ignite flammable vapors. To help prevent fire and explosion:</p> <ul style="list-style-type: none"> • Clean plastic parts only in well-ventilated area. • Do not clean with a dry cloth.



WARNING

**ELECTRIC SHOCK HAZARD****Explosive Atmospheres or Hazardous (Classified) Locations Models (hard wired for permanent connection):**

This equipment must be grounded. Improper grounding, setup, or usage of the system can cause electric shock.

- Turn off and disconnect power at main switch before disconnecting any cables and before servicing or installing equipment.
- Connect only to grounded power source.
- All electrical wiring and repairs must be done by a qualified electrician and comply with all local codes and regulations.
- Store indoors.

**Ordinary Locations Models (cord and plug connection)**

This equipment must be grounded. Improper grounding, setup, or usage of the system can cause electric shock.











- Turn off and disconnect power cord before servicing equipment.
- Connect only to grounded electrical outlets.
- Only use 3-wire extension cords for 2-phase models. Only use 4-wire extension cords for 3-phase models.
- Ensure ground prongs are intact on power and extension cords.
- Store indoors.
- Wait five minutes after disconnecting power cord before servicing.

**EQUIPMENT MISUSE HAZARD**





Misuse can cause death or serious injury.

- Do not operate the unit when fatigued or under the influence of drugs or alcohol.
- Do not exceed the maximum working pressure or temperature rating of the lowest rated system component. See **Technical Specifications** in all equipment manuals.
- Use fluids and solvents that are compatible with equipment wetted parts. See **Technical Specifications** in all equipment manuals. Read fluid and solvent manufacturer's warnings. For complete information about your material, request Safety Data Sheets (SDSs) from distributor or retailer.
- Turn off all equipment and follow the **Pressure Relief Procedure** when equipment is not in use.
- Check equipment daily. Repair or replace worn or damaged parts immediately with genuine manufacturer's replacement parts only.
- Do not alter or modify equipment. Alterations or modifications may void agency approvals and create safety hazards.
- Make sure all equipment is rated and approved for the environment in which you are using it.
- Use equipment only for its intended purpose. Call your distributor for information.
- Route fluid lines, cords, and cables away from traffic areas, sharp edges, moving parts, and hot surfaces.
- Do not kink or over-bend fluid lines, cords, or cables. Do not use fluid lines, cords, or cables to pull equipment.
- Keep children and animals away from work area.
- Comply with all applicable safety regulations.



 <h1 style="margin: 0;">WARNING</h1>	
 	<p>PLASTIC PARTS CLEANING SOLVENT HAZARD</p> <p>Many cleaning solvents can degrade plastic parts and cause them to fail, which could cause serious injury or property damage.</p> <ul style="list-style-type: none"> • Use only compatible solvents to clean plastic structural or pressure-containing parts. • See Technical Specifications in all equipment manuals for materials of construction. Consult the solvent manufacturer for information and recommendations about compatibility.
  	<p>PRESSURIZED EQUIPMENT HAZARD</p> <p>Fluid from the equipment, leaks, or ruptured components can splash in the eyes or on skin and cause serious injury.</p> <ul style="list-style-type: none"> • Follow the Pressure Relief Procedure when you stop spraying/dispensing and before cleaning, checking, or servicing equipment. • Tighten all fluid connections before operating the equipment. • Check fluid lines and connections daily. Replace worn or damaged parts immediately.
	<p>PRESSURIZED ALUMINUM PARTS HAZARD</p> <p>Use of fluids that are incompatible with aluminum in pressurized equipment can cause serious chemical reaction and equipment rupture. Failure to follow this warning can result in death, serious injury, or property damage.</p> <ul style="list-style-type: none"> • Do not use 1,1,1-trichloroethane, methylene chloride, other halogenated hydrocarbon solvents or fluids containing such solvents. • Do not use chlorine bleach. • Many other fluids may contain chemicals that can react with aluminum. Contact your material supplier for compatibility.
  	<p>THERMAL EXPANSION HAZARD</p> <p>Fluids subjected to heat in confined spaces, including fluid lines, can create a rapid rise in pressure due to the thermal expansion. Over-pressurization can result in equipment rupture and serious injury.</p> <ul style="list-style-type: none"> • Open a valve to relieve the fluid expansion during heating. • Replace fluid lines proactively at regular intervals based on your operating conditions.

WARNING

 	<p>ENTANGLEMENT HAZARD Rotating parts can cause serious injury.</p> <ul style="list-style-type: none"> • Keep clear of moving parts. • Do not operate equipment with protective guards or covers removed. • Do not wear loose clothing, jewelry or long hair while operating equipment. • Equipment can start without warning. Before checking, moving, or servicing equipment, follow the Pressure Relief Procedure and disconnect all power sources.
	<p>TOXIC FLUID OR FUMES HAZARD Toxic fluids or fumes can cause serious injury or death if splashed in the eyes or on skin, inhaled, or swallowed.</p> <ul style="list-style-type: none"> • Read Safety Data Sheets (SDSs) to know the specific hazards of the fluids you are using. • Store hazardous fluid in approved containers, and dispose of it according to applicable guidelines.
	<p>BURN HAZARD Equipment surfaces and fluid that is heated can become very hot during operation. To avoid severe burns:</p> <ul style="list-style-type: none"> • Do not touch hot fluid or equipment.
	<p>PERSONAL PROTECTIVE EQUIPMENT Wear appropriate protective equipment when in the work area to help prevent serious injury, including eye injury, hearing loss, inhalation of toxic fumes, and burns. Protective equipment includes but is not limited to:</p> <ul style="list-style-type: none"> • Protective eyewear, and hearing protection. • Respirators, protective clothing, and gloves as recommended by the fluid and solvent manufacturer.

Configuration Matrix

Record the model part number and configuration sequence found on your equipment identification plate (ID) to assist you when ordering replacement parts.

Model Part Number:

Configuration Sequence:

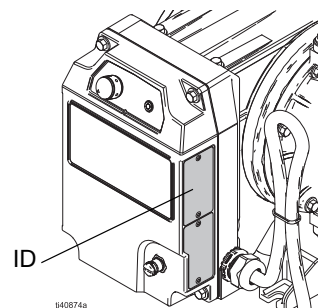

Sample Configuration Sequence: VA-2E25AD1ACACBNTN00									
VA	2E	25	A	D1	AC	AC	BN	TN	00
Brand	Application	Model	Wetted Section Material	Motor	Seat Material	Check Material	Diaphragm Material	Connection	Options

NOTE: Some combinations are not possible. Check with your local distributor.

Brand		Application		Model		Wetted Section Material	
VA	VERDERAIR	2E	Industrial (i)	25	1 in. port	A	Aluminum
				40	1-1/2 in. port	I	Cast Iron
				50	2 in. port	C	Conductive Polypropylene
						P	Polypropylene
						K	PVDF
						S	316 Stainless Steel

Motor - Industrial Models						
Drive		Coat	Input Voltage	Phase	Location	Cord/Cable Termination
D1	Aluminum Direct Drive	Black powder coat	200-240 V	3-Phase	Industrial, Ordinary Locations	Cord with plug
D2	Aluminum Direct Drive	Black powder coat	200-240 V	Single-Phase	Industrial, Ordinary Locations	Cord with plug
D3	Aluminum Direct Drive	Black powder coat	200-240 V	3-Phase	Industrial, Hazardous (Classified) Locations	Cable with flying leads
D4	Aluminum Direct Drive	Black powder coat	200-240 V	Single-Phase	Industrial, Explosive Atmospheres	Cable with flying leads
D5	Aluminum Direct Drive	Black powder coat	100-120 V	Single-Phase	Industrial, Ordinary Locations	Cord with plug
D6	Aluminum Direct Drive	Black powder coat	100-120 V	Single-Phase	Industrial, Hazardous (Classified) Locations	Cable with flying leads





Configuration Matrix

Seat Material		Check Material		Diaphragm Material	
AC	Acetal	AC	Acetal, ball	BN	Buna-N
AL	Aluminum	BN	Buna-N, ball	NO	Polychloroprene Overmold
BN*	Buna-N	NE	Polychloroprene, standard, ball	VT	Fluoroelastomer
VT*	Fluoroelastomer	NW	Polychloroprene, weighted, ball	GE	Geolast
GE	Geolast	VT	Fluoroelastomer, ball	TO	PTFE/EPDM Overmold
PP	Polypropylene	GE	Geolast, ball	TS	PTFE/Santoprene, two-piece
KY	PVDF	TF	PTFE, ball	SP	Santoprene
HS	17-4PH Stainless Steel with PTFE seals	HS	440C Stainless Steel, ball	HY	TPE
SP	Santoprene	SP	Santoprene, ball		
SS	316 Stainless Steel	SS	316 Stainless Steel, ball		
HY*	TPE	HY	TPE, ball		

* Models with BN, VT, or HY seats do not use manifold seals.

Connection		Options	
TN	Threaded NPT - IND	00	Standard
TB	Threaded BSP - IND		
FC	Center Flange DIN/ANSI - IND		
FE	End Flange DIN/ANSI - IND		
FCH	Center Flange DIN/ANSI Horizontal		

Approvals

Model Information*	Approvals
Motors	For motor approvals, see your related motor manual. See Related Manuals , page 2.
Pump models with motor code D2 are approved to:	 
Pump models with motor code D4 are approved to:	   II 2 G Ex dh IIB T4 Gb

* See **Configuration Matrix**, starting on page 6, for detailed descriptions.

Component Identification

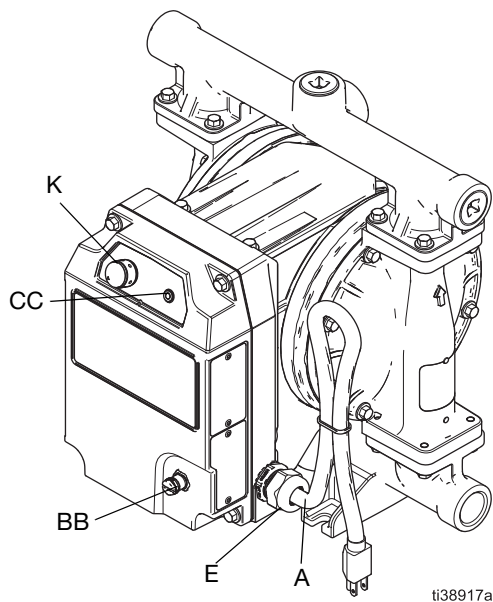

FIG. 1: Ordinary Locations Model (VA-2E25 model shown)

Ordinary Locations models include a cord with a plug and Input/Output (I/O) port.

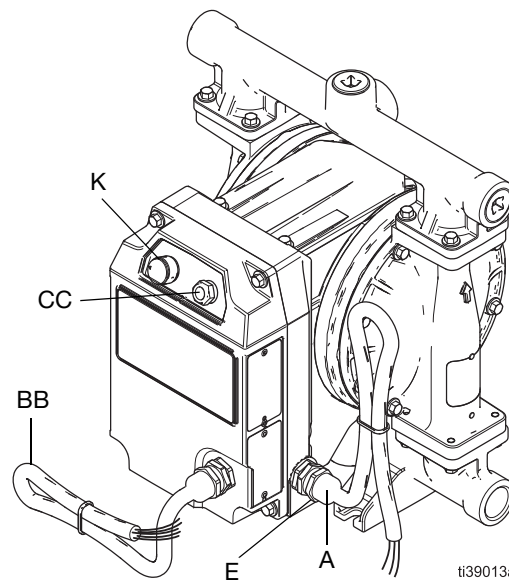



FIG. 2: Explosive Atmospheres or Hazardous (Classified) Locations Model (VA-2E25 model shown)

Explosive Atmospheres or Hazardous (Classified) Locations models include flying leads on the power cable (for direct wiring to a power source).

Ref.	Component	Ordinary Locations Models	Explosive Atmospheres or Hazardous (Classified) Locations Models
A	Power Cord/Cable	4.6 m (15 ft) cord with plug*	4.6 m (15 ft) cable for hard-wiring†
BB	I/O Port/Cable On/Off Control, Digital Input Run Status, Digital Output Speed and Pressure Control, Analog Input	M12, 5-pin connector**	Cable (not supplied) for direct wiring to user-provided controls‡
CC	LED Indicator♦	Standard	Reinforced
E	External Ground Fastener, Ground Symbol	The equipment is marked per IEC 417, Symbol 5019: 	
K	Control Knob	Turn clockwise (right) to increase fluid output	

* See **Required Power and Plugs**, page 17.

** See **I/O Pin Connection**, page 20.

† See **Wire Power Cables**, page 18, and **Wiring for 3-Phase Models**, page 18.

‡ I/O cable kits are available (purchase separately). See your related motor manual. See **Related Manuals**, page 2.

♦ See **LED Indicator**, page 25.

Typical Installation

General Information

Typical installations are shown in FIG. 3 and FIG. 4. The figures are only guides for selecting and installing system components. Contact your local distributor for assistance in planning a system to suit your needs. Be

sure all accessories are adequately sized and pressure-rated to meet the requirements of the system.

Reference letters in the text, for example, (A), refer to the callouts in the figures.

Typical Installation for Models in Ordinary Locations

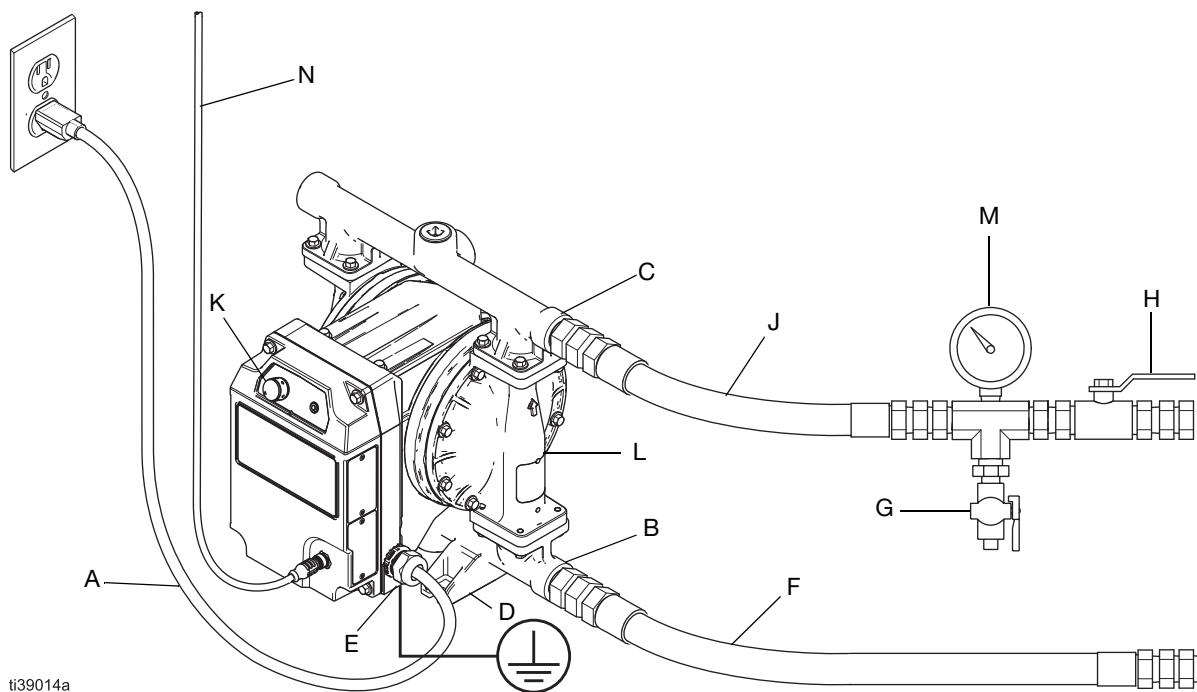

ti39014a

FIG. 3: Typical Installation for Models in Ordinary Locations (cord and plug connection) (VA-2E25 model shown)

Pump Components

- A♦ Power cord
- B Fluid inlet port
- C Fluid outlet port
- D Mounting feet
- E Ground fastener
- K Fluid output control knob
- L▼ Diaphragm access ports (not shown)

Accessories (Not Supplied)

- F* Conductive, flexible fluid supply line
- G* Fluid drain valve
- H Fluid shutoff valve
- J* Conductive, flexible fluid outlet line
- M Fluid pressure gauge
- N I/O Cable

♦ Connect to a circuit with a main electrical disconnect. Install a branch circuit protective device in each ungrounded phase. Follow local codes and regulations.

* Required, not supplied.

▼ See *Install Monitoring Accessories*, page 14, or *Install Fluid Leak Line Accessories*, page 14.

Typical Installation for Models in Explosive Atmospheres or Hazardous (Classified) Locations

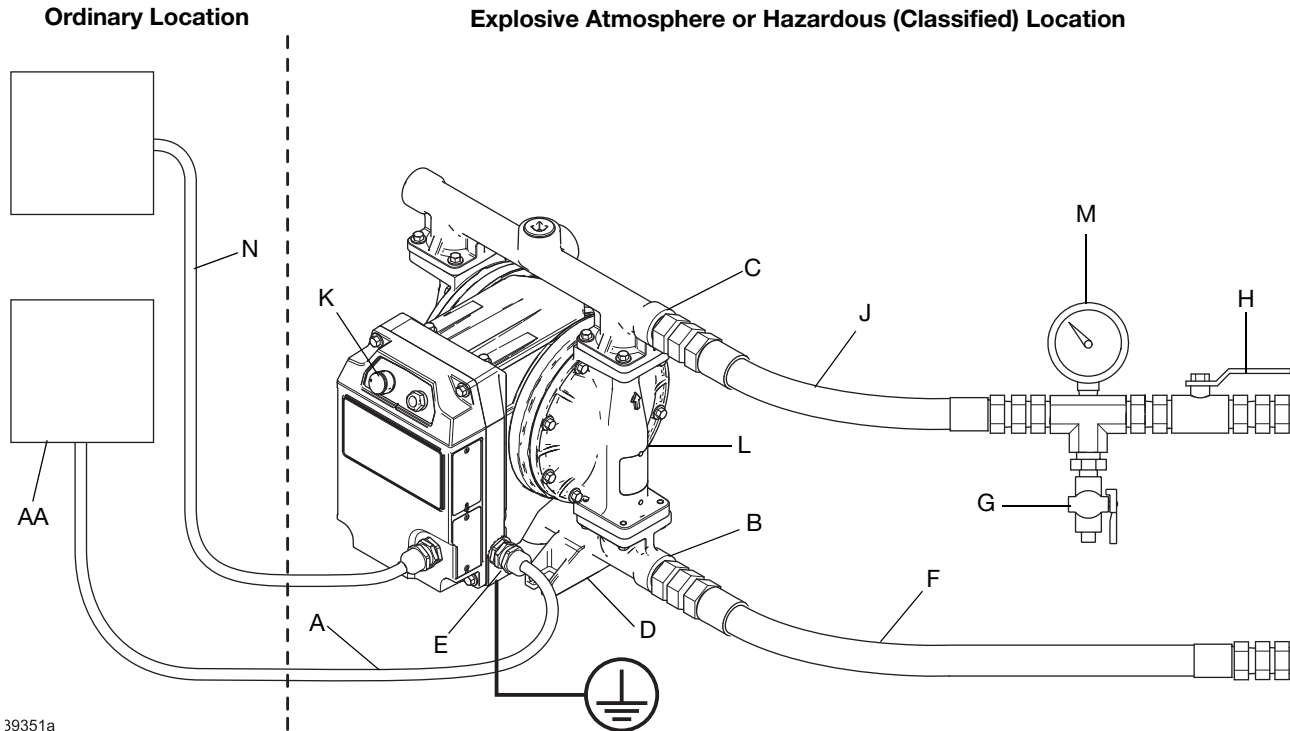

39351a

FIG. 4: Typical Installation for Models in Explosive Atmospheres or Hazardous (Classified) Locations (hard wired for permanent connection) (VA-2E25 model shown)

Pump Components

- A**♦ Power cable
- B** Fluid inlet port
- C** Fluid outlet port
- D** Mounting feet
- E** Ground fastener
- K** Fluid output control knob
- L**▼ Diaphragm access ports (not shown). Diaphragm access ports must not be open in hazardous locations. Ports must have installed either plugs 814-0346 (as shipped from the factory), or leak sensor kit 814-0295.

♦ Connect to a circuit with a main electrical disconnect. Install a branch circuit protective device in each ungrounded phase. Follow local codes and regulations.

▼ See **Install Monitoring Accessories**, page 14, or **Install Fluid Leak Line Accessories**, page 14.

Accessories (Not Supplied)

- F*** Conductive, flexible fluid supply line
- G*** Fluid drain valve
- H** Fluid shutoff valve
- J*** Conductive, flexible fluid outlet line
- M** Fluid pressure gauge
- N***‡ I/O Cable
- AA** Electrical disconnect

* Required, not supplied.

‡ I/O cable kits are available (purchase separately). See your related motor manual. See **Related Manuals**, page 2.

Installation

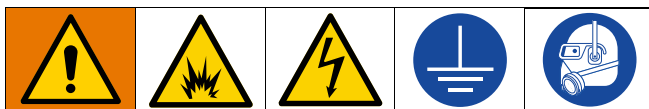

Installation of this equipment involves potentially hazardous procedures. Only trained and qualified personnel who have read and who understand the information in this manual should install this equipment.

To avoid injury from fire, explosion, or electric shock, all electrical wiring must be done by a qualified electrician and comply with all local codes and regulations.

Mount the Pump



The pump may be very heavy (see **Technical Specifications**, starting on page 50, for specific weights). Use at least two straps and appropriate lifting equipment or have two people lift the pump. Do not use the outlet manifold alone to lift the pump.

1. Ensure that the mounting surface is level.
2. Ensure that the mounting surface and mounting hardware is strong enough to support the weight of the pump, fluid lines, accessories, and fluid, as well as the stress caused during operation.
3. For all mountings, be sure the pump is secured with fasteners through the mounting holes on the base. See FIG. 5. See **Dimensions**, starting on page 44.

NOTE: For ease of operation and service, mount the pump so the control knob (K), LED indicator (CC), I/O port/cable (BB), and fluid inlet and outlet ports (B, C) are easily accessible.

NOTICE

To avoid pump damage, mount the pump to the mounting location using fasteners through each hole of the feet. See FIG. 5.

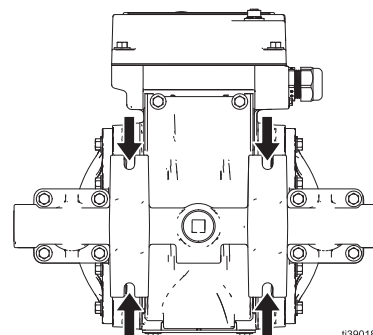

FIG. 5: Mounting Holes

Connect Fluid Lines

Use conductive, flexible fluid lines for fluid supply (F) and fluid outlet (J) lines.

1. Install conductive, flexible fluid lines (F and J).
2. Install a fluid drain valve (G) near the fluid outlet. See FIG. 3 and FIG. 4.



A fluid drain valve (G) is required to relieve pressure in the fluid outlet line. The drain valve reduces the risk of serious injury, including splashing in the eyes or on the skin, when relieving pressure.

3. Install a fluid shutoff valve (H) in the fluid outlet line (J) downstream from the fluid drain valve (G).

NOTE: Install the equipment as close as possible to the material source. See **Technical Specifications**, starting on page 50, for maximum suction lift.

NOTICE

The pump can be damaged if flexible fluid lines are not used. If hard-plumbed fluid lines are used in the system, use a short length of conductive, flexible fluid line to connect to the pump.

Install Accessories

Install Monitoring Accessories

Install the following accessory to monitor equipment performance.

- **Leak Sensor:** Monitors for leaks in the pump due to diaphragm rupture. Automatically stops pump operation and triggers the LED Indicator if a leak is detected. Not provided with the equipment. Accessory kits are available (purchase separately). See **Related Manuals**, page 2.

NOTICE

To avoid pump damage, install a leak sensor to detect leaks in the equipment due to diaphragm rupture.

Install Fluid Line Accessories

Install the following accessories in the order shown in FIG. 3 and FIG. 4, using adapters as needed.

- **Fluid drain valve (G):** Required. Relieves fluid pressure in the system.
- **Fluid shutoff valve (H):** Shuts off fluid flow.
- **Fluid pressure gauge (M):** For more precise adjustment of the fluid pressure.
- **Fluid outlet line (J):** Required. To dispense fluid.
- **Fluid supply line (F):** Required. Enables the equipment to draw fluid from a container.

Install Fluid Leak Line Accessories



If a leak sensor is not installed in the pump and the diaphragm ruptures, the equipment will fill with fluid or fluid will drain into the work area. To avoid injury from leaking fluid, toxic fluid, toxic fumes, splashing fluid, or hot fluid, install fluid drain lines to route fluid leaks due to diaphragm rupture.

NOTICE

To avoid pump damage due to diaphragm rupture, install a leak sensor to detect leaks in the equipment and automatically stop pump operation. See **Install Monitoring Accessories**, page 14.

If a leak sensor is not installed in the pump, install the following accessory as shown in FIG. 6, using adapters as needed.

NOTE: To monitor for leaks in the pump due to diaphragm rupture, install a leak sensor. See **Install Monitoring Accessories**, page 14.

- **Fluid Leak line (L2):** Routes fluid to a drain location if fluid leaks due to diaphragm rupture.
1. Remove the plugs (if applicable) in the diaphragm access ports (L).
 2. Install conductive, flexible fluid leak lines (L2) to the diaphragm access ports (L).
 3. Route the fluid leak lines (L2) to a grounded end container (L3) to catch leaking fluid. Follow local codes and regulations for grounding.

NOTE: For Models in Explosive Atmospheres or Hazardous (Classified) Locations: Ensure the end container is grounded and located in a non-explosive or non-hazardous environment. Diaphragm access ports must not be open in hazardous locations. Ports must have installed either plugs 814-0346 (as shipped from the factory), or leak sensor kit 814-0295.

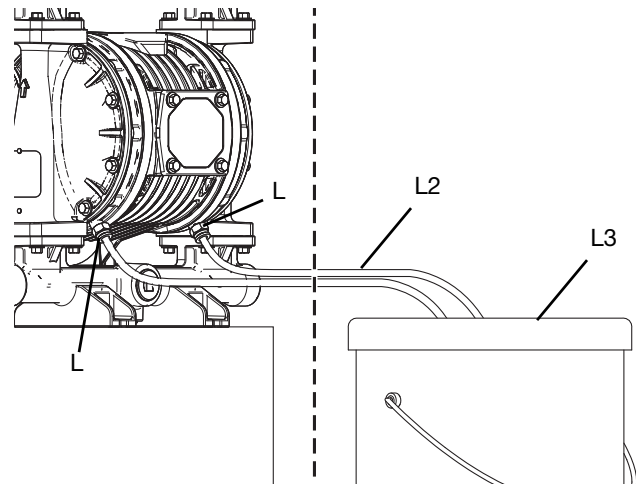





Fig. 6: Typical Installation of Fluid Leak Lines (Ordinary Locations)

Grounding

				
<p>The equipment must be grounded to reduce the risk of static sparking and electric shock. Electric or static sparking can cause fumes to ignite or explode. Improper grounding can cause electric shock. Grounding provides an escape wire for the electric current.</p> <ul style="list-style-type: none"> • Always ground the entire fluid system as described in this section. • Follow local codes and regulations. 				

Before operating the equipment, ground the system as follows.

Ground the Pump

Connect a Static Ground

See FIG. 7.

1. Loosen the ground fastener (E).
2. Insert one end of a 4 mm² (12-gauge) or thicker ground wire behind the ground fastener and securely tighten the ground fastener (E).
3. Connect the clamp end of the ground wire to a true earth ground.

NOTE: A ground wire and clamp (part number 819-0673) is available (purchase separately).

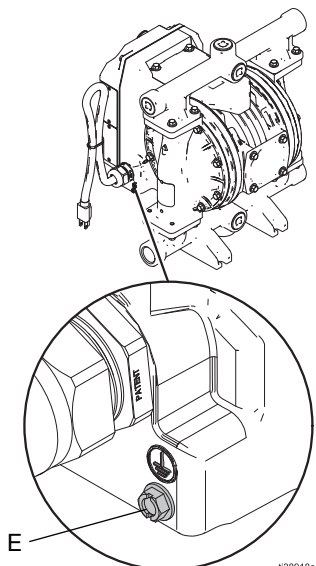

FIG. 7: Equipment Ground Fastener

Connect the Electrical Ground

For Models in Explosive Atmospheres or Hazardous (Classified) Locations: Ground through the ground wire of the power cable to a true earth ground. Connect the ground wire of the power cable to a true earth ground. See **Electrical Connections and Wiring**, starting on page 17.

For Models in Ordinary Locations: Ground through the provided power cord and plug. Connect the plug to a power outlet that is properly installed and grounded to a true earth ground.

Ground the Fluid Lines

Use only conductive fluid lines with a maximum of 150 m (500 ft) combined line length to ensure grounding continuity. Check electrical resistance of the fluid lines.

Ground the Fluid Supply Container

Follow local codes and regulations.

Ground the Pails for Solvents and Sanitizing Solution Used when Flushing

Follow local codes and regulations. Use only conductive metal pails, placed on a grounded surface. Do not place the pail on a non-conductive surface, such as paper or cardboard, which interrupts grounding continuity.

Verify Ground Continuity

Check the pump ground continuity after the initial installation. Set a regular schedule for checking ground continuity to maintain proper grounding. Do not exceed 1 ohm resistance from earth ground to the pump.

Before First Use

Tighten Fasteners

Before using the equipment for the first time, check and torque all fasteners. Follow **Torque Fasteners**, page 39.

After the first day of operation, re-torque the fasteners.

NOTICE

To avoid pump damage, do not over-torque the fasteners on the equipment.

Tighten Connections

Check and tighten all fluid connections before operating the equipment. Replace worn or damaged parts as needed.

NOTICE

Firmly tighten all connections to avoid leaks and damage to equipment parts.



Flush the Equipment

Before using the equipment for the first time, flush the equipment. Follow **Flush the Equipment**, page 28.

The equipment was tested with water. If water could contaminate the fluid being dispensed, flush the equipment with a compatible solvent before first use.





Electrical Connections and Wiring

Required Power and Plugs

				
To avoid injury from fire, explosion, or electric shock, all electrical wiring must be done by a qualified electrician and comply with all local codes and regulations.				

NOTE: For equipment provided with a cable and flying leads (no plug), install a main electrical disconnect per local codes and regulations.

NOTE: Use adapters as needed. Follow local codes and regulations.

Required Power and Plugs								
Location	Motor Configuration Code*	Model	Power Requirements				Cord/Cable Termination	Plug
			Input Voltage	Phase [‡]	Hertz	Current		
Ordinary Locations	D1	VA-2E25, VA-2E40, VA-2E50	200–240 V	3	50/60 Hz	7.5 A	NEMA L15-20 Plug	
	D2	VA-2E25	200–240 V	1	50/60 Hz	10 A	IEC 60320-C14 Plug [♦]	
		VA-2E40, VA-2E50	200–240 V	1	50/60 Hz	15 A	IEC 60320-C20 Plug [♦]	
	D5	VA-2E25	100–120 V	1	50/60 Hz	12 A	NEMA 5-15 Plug	
Hazardous (Classified) Locations	D3	VA-2E25, VA-2E40, VA-2E50	200–240 V	3	50/60 Hz	7.5 A	Flying Leads, see FIG. 10	For permanent connection [■]
	D6	VA-2E25	100–120 V	1	50/60 Hz	12 A	Flying Leads, see FIG. 9	
Explosive Atmospheres	D4	VA-2E25	200–240 V	1	50/60 Hz	10 A	Flying Leads, see FIG. 9	
		VA-2E40, VA-2E50	200–240 V	1	50/60 Hz	15 A		

* See **Configuration Matrix**, starting on page 6, for detailed descriptions.

[‡] Connect to a circuit with a main electrical disconnect. Install a branch circuit protective device in each ungrounded phase. Follow local codes and regulations.

■ See **Wire Power Cables**, page 18.

♦ Adapters are available (purchase separately). See **Adapters for Plugs and Cables**, page 19.

Wire Power Cables



To avoid injury from fire, explosion, or electric shock, all electrical wiring must be done by a qualified electrician and comply with all local codes and regulations.

For models in Explosive Atmospheres or Hazardous (Classified) Locations only.

To connect an Explosive Atmospheres or Hazardous (Classified) Locations model to a power source, complete one of the following:

- Hard wire the equipment to a power source.
- Supply a plug, socket, and interlocking device that meets the requirements of EN 60079-0 or UL 674.

NOTE: See **Required Power and Plugs**, page 17, for power requirements. Install a branch circuit protective device in each ungrounded phase.

A 4.6 m (15 ft) cable (either 3-conductor or 4-conductor) is provided with models for Explosive Atmospheres or Hazardous (Classified) Locations. Connect the cable directly to a panel with branch circuit protection and an electrical disconnect per local codes and regulations. If additional length of cable is required, connect additional cable through a junction box. Use the following table to select the minimum cable wire gauge based on length:

Length	Gauge	mm ²
15.2 m (50 ft)	12 AWG	4
30.4 m (100 ft)	10 AWG	6
61 m (200 ft)	8 AWG	10

NOTE: Ensure that the electrical disconnect (AA) is shut off and locked out before wiring. See FIG. 8.

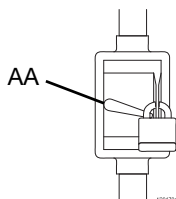
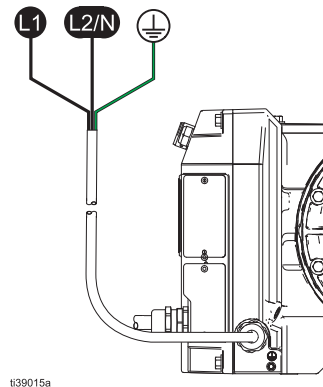

FIG. 8: Electrical Disconnect

Wire Single-Phase Models

For models in Explosive Atmospheres or Hazardous (Classified) Locations only. See FIG. 9.

1. **D6 motors:** Connect the black wire to Line 1 (L1, black).
- D4 motors:** Connect the brown wire to Line 1 (L1, brown).
2. **D6 motors:** Connect the white wire to Neutral (L2/N, white).
- D4 motors:** Connect the blue wire to Line 2 (L2/N, blue).
3. Connect the ground wire (green or green with yellow stripe) to a true earth ground.



839015a

FIG. 9: Wiring for Single-Phase Models

Wire 3-Phase Models

For models in Explosive Atmospheres or Hazardous (Classified) Locations only. See FIG. 10.

1. Connect the black wire to Line 1 (black, L1).
2. Connect the white wire to Line 2 (white, L2).
3. Connect the red wire to Line 3 (red, L3).
4. Connect the ground wire (green or green with yellow stripe) to a true earth ground.

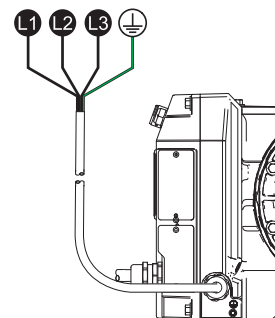





840182a

FIG. 10: Wiring for 3-Phase Models

Requirements for Cables and Conduits

For models in Explosive Atmospheres or Hazardous (Classified) Locations only.

				
<p>Do not modify or repair explosion proof joints. Modifying explosion proof joints may produce an explosion hazard.</p> <p>To avoid injury from fire, explosion, or electric shock, all electrical wiring must be done by a qualified electrician and comply with all local codes and regulations.</p>				

Requirements for Explosion Proof Equipment

Use appropriate conduits, connectors, and cable glands rated for Class I, Division I, Group D. Follow all national, state, and local electric codes and regulations.

Cable rating requirement: 70°C (158°F) minimum (all cables)

Cable gland rating requirement: 70°C (158°F) minimum (all glands)





Requirements for Flame Proof Equipment

Use appropriate conduits, connectors, and cable glands rated for Ex II 2 G. Follow all national, state, and local electric codes and regulations.

Cable rating requirement: 70°C (158°F) minimum (all cables)





Cable gland rating requirement: 70°C (158°F) minimum (all glands)

Adapters for Plugs and Cables

				
<p>To avoid injury from fire, explosion, or electric shock, all electrical wiring must be done by a qualified electrician and comply with all local codes and regulations.</p>				

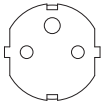
Use adapters as needed. Follow local codes and regulations.

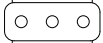
Adapters are available (purchase separately).

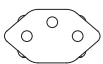
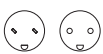
Plug Adapters			
Region	Part		Plug Adapter
	C14 Plugs	C20 Plugs	
Europe	814-0339	814-0337	
Australia, China	814-0338	814-0336	
Italy	---	814-0335	
Italy	814-0340 Kit contains all three C14 Plugs	---	
Switzerland		814-0334	
Denmark		---	

Plug Retainer Clips	
Plug	Part
C14 Plugs	814-0341
C20 Plugs	814-0341

I/O Port Flying Lead Cable Adapters (for models in Ordinary Locations only)	
Cable Length (meters)	Part
2	814-0342
15	814-0343
30	814-0344

I/O Pin Connection

				
<p>To avoid injury from fire, explosion, or electric shock, all electrical wiring must be done by a qualified electrician and comply with all local codes and regulations.</p>				

For models in Ordinary Locations only.

NOTE: All I/O connectors are capable of 30 VDC (volts of direct current) and are reverse-polarity protected.

For wiring, see **Equivalent Electrical Circuits for I/O Pin Connection**, page 21.

I/O Connector Pinout (for Models in Ordinary Locations only)		
Pin	Connector Type	Description
Pin 1	Digital Input	Digital input has an internal 5 VDC pull-up for dry-contact or current-sinking circuits. Digital input is internally clamped for push-pull outputs. Release or drive the input high to stop the equipment from running. Pull the input low to re-enable the equipment.
Pin 2	Digital Output (Equipment Running)	Digital output is current-sinking with a current capacity up to 100 mA. Digital output is internally clamped for driving large inductive loads. The output is automatically pulled low when the equipment is running and automatically released when the equipment is not running.
Pin 3	GND/Common	Earth ground, common connection.
Pin 4	Analog Input, Positive	<p>Analog inputs are 4–20 mA current-controlled. When the analog input is connected and driving current, the equipment disables the control knob (K) and uses the analog input to control the speed and pressure of the equipment. The control knob (K) can still be used to shut off the equipment by turning the knob to off (0). To re-enable the equipment at the speed and pressure commanded by the analog input, turn the control knob up (clockwise).</p> <p>To disable the analog input control and enable the control knob (K):</p> <ol style="list-style-type: none"> 1. Shut down the equipment. See Shut Down the Equipment, page 24. Ensure the LED indicator is off (no light). 2. Disconnect power to the system. 3. Disconnect the analog input (Pin 4, Pin 5). 4. Connect the unit to a power source to turn on the equipment and enable the control knob (K) on the equipment.
Pin 5	Analog Input, Negative	

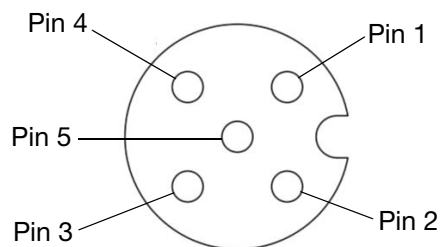

FIG. 11: M12, 5-pin Connector for Models in Ordinary Locations

Equivalent Electrical Circuits for I/O Pin Connection

Equivalent Electrical Circuits for I/O Pin Connection (for Models in Ordinary Locations only)	
I/O Circuit	Equivalent Circuit
Digital Input	<p>5 VDC</p> <p>4.7 Kiloohms</p> <p>M12, Pin 1</p> <p>+</p> <p>Logic: Low (Run) < 2.0 V High (Stop) > 3.0 V</p> <p>- M12, Pin 3</p> <p>Maximum 30 VDC</p>
	Compatible Drivers for Digital Input
	<p>Switch or Relay</p>
	<p>Open Collector (NPN)</p>
	<p>Push-Pull Driver</p> <p>Maximum 30 VDC</p>

Equivalent Electrical Circuits for I/O Pin Connection (for Models in Ordinary Locations only)	
I/O Circuit	Equivalent Circuit
Digital Output	<p>M12, Pin 2</p> <p>+</p> <p>Maximum 30 VDC, Maximum 100 mA</p> <p>- M12, Pin 3</p> <p>Logic: Pump Running: Active Pump Stopped: Inactive</p>
Analog Input	<p>Maximum 30 VDC</p> <p>M12, Pin 4</p> <p>+</p> <p>440 Ohms</p> <p>Maximum 2.0 W</p> <p>- M12, Pin 5</p>

Operation

Pressure Relief Procedure

 Follow the Pressure Relief Procedure whenever you see this symbol.



This equipment stays pressurized until pressure is manually relieved. To help prevent serious injury from pressurized fluid, such as splashing fluid and moving parts, follow the **Pressure Relief Procedure** when you stop operating and before cleaning, checking, or servicing the equipment.

1. Turn the fluid output control knob (K) to off (0) and disconnect power to the system.
2. Close the fluid shutoff valve (H).
3. Open the fluid drain valve (G) to relieve fluid pressure. Prepare a container to catch the drainage.
4. Leave the fluid drain valve (G) open until the system is ready to be pressurized.

Before Each Use

Tighten Fasteners

Check and tighten all fasteners before operating the equipment. Re-torque as needed. Follow **Torque Fasteners**, page 39.

NOTICE

To avoid pump damage, do not over-torque the fasteners on the equipment.

Tighten Connections

Check and tighten all fluid connections before operating the equipment. Replace worn or damaged parts as needed.

NOTICE

Firmly tighten all connections to avoid leaks and damage to equipment parts.

Flush the Equipment

Flush the equipment before each use. Determine whether to disassemble and clean individual parts or simply flush the equipment with a compatible solvent.

To simply flush the equipment with a compatible solvent, follow **Start the Equipment**, page 22, and **Flush the Equipment**, page 28.

To disassemble and clean individual parts, see the applicable repair procedure. See **Repair**, starting on page 32.

Start the Equipment



To prevent serious injury from splashing fluid, ensure the control knob (K) is set to off (0) before connecting the equipment to a power source.

Prepare the Equipment for Startup

1. Turn the control knob (K) to off (0).
2. Confirm that the equipment is properly grounded. See **Grounding**, page 15.
3. Check and tighten all fasteners and connections before operating the equipment. Replace worn or damaged parts as needed.
4. Insert the suction end of the fluid supply line (F) into the fluid to be dispensed.
5. Insert the outlet end of the fluid outlet line (J) into the end container.
6. Close the fluid drain valve (G).
7. Ensure all fluid shutoff valves (H) are open.
8. If the fluid outlet line (J) has a dispensing device, hold the dispensing valve open into the end container.

Start and Adjust the Equipment

1. Follow **Prepare the Equipment for Startup**, page 22.
2. Connect the equipment to a power source. See **Electrical Connections and Wiring**, starting on page 17.

NOTE: The pump will automatically start cycling if the pump is connected to power and the control knob (K) is not set to off (0).

3. After the alert beep sounds, allow the equipment to complete the startup sequence. See **LED Indicator Overview**, page 25.

The LED indicator light illuminates solid yellow while calibrating. The pump cycles slowly while adjusting and operates normally after fully calibrating.

The system stays calibrated as long as power to the system is connected. If power to the system is disconnected, the system will automatically recalibrate after power is restored.

4. Slowly increase the control knob (K) until the equipment is operating at the set output level.
5. If flushing, run the equipment long enough to thoroughly clean the equipment and lines.

Tips to Reduce Cavitation

NOTICE

Frequent or excessive cavitation can cause serious damage, including pitting and early wear of wetted parts, and may result in reduced efficiency of the equipment. Cavitation damage and reduced efficiency both result in increased operating costs.

Cavitation is the formation and collapse of air pockets in the fluid. Cavitation depends on the vapor pressure of the fluid, the system suction pressure, and the velocity pressure. Viscous fluids are more difficult to pump and more prone to cavitation than non-viscous fluids.

To improve equipment efficiency and reduce the cavitation:

1. **Reduce vapor pressure:** Decrease the temperature of the fluid.
2. **Increase suction pressure:**
 - a. Position the equipment lower than the fluid level in the supply.

- b. Reduce the number of fittings on the suction lines to reduce friction length.
- c. Increase the diameter of the suction lines.
- d. Reduce the fluid inlet pressure. An inlet pressure supply of 21–35 kPa, 0.2–0.3 bar (3–5 psi) is adequate for most materials.

NOTICE

To avoid pump damage and inefficient operation, do not use a fluid inlet pressure greater than 25 percent of the outlet working pressure.

- e. Increase the Net Positive Suction Head (NPSH). See **Performance Charts**, page 42.

3. **Reduce liquid velocity:** Slow the equipment cyclic rate.

Consider all the previously listed factors in system design. To maintain efficiency, operate the equipment at the lowest speed and pressure setting needed for the required flow.

Contact your local distributor for site-specific suggestions to improve equipment performance and reduce operating costs.

Disable Auto-Prime

The auto-prime sensor detects fluid while the equipment is operating. The equipment will run as long as fluid is detected. If fluid is not detected, the auto-prime sequence will restart.

Auto-prime is enabled by default. To disable auto-prime:

1. Follow **Remove the Control Cover**, in the control cover repair procedures in the motor manual. See **Related Manuals** on page 2.
2. Locate the auto-prime switch (AP). See FIG. 12 or **Electrical Schematics** in the motor manual.
3. Push the auto-prime switch (AP) to the left (off) position.
4. Follow **Install the Control Cover** in the control cover repair procedures in the motor manual.

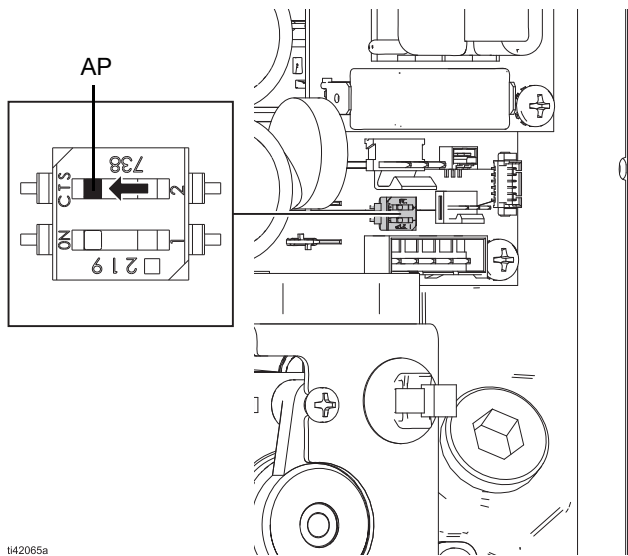

FIG. 12: Disable Auto-Prime

Shut Down the Equipment



1. Follow **Pressure Relief Procedure**, page 22.
2. Follow **Flush the Equipment**, page 28.

LED Indicator

LED Indicator Overview

LED Indicator	Equipment Status	Notes
Red, solid	Powered on, speed set at 0 (zero), system not operating.	Be aware that the equipment is energized. To initiate equipment operation, follow Start the Equipment , page 22.
Red, flashing	Motor fault, motor error.	See Troubleshoot LED Indicator Event Errors , page 26.
Yellow, solid	Calibrating. Performing startup sequence.	No action. Allow equipment to finish startup sequence. Open the fluid drain valve (G) or fluid shutoff valve (H) to allow the equipment to cycle until the startup sequence is finished.
Yellow, flashing	Leak sensor alert.	See “Leak sensor alert” Troubleshoot LED Indicator Event Errors , page 27.
Green, solid	Startup sequence complete.	To initiate equipment operation, follow Start the Equipment , page 22.
	Normal operation.	No action.
Green, flashing	Normal operation, stalled against pressure.	Be aware that the equipment is energized. Special-case action. See Troubleshoot LED Indicator Event Errors , page 26.
No light (off)	System not powered.	See Troubleshoot LED Indicator Event Errors , page 26.

Troubleshoot LED Indicator Event Errors

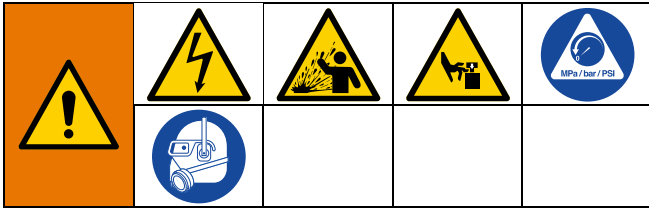

If an event error occurs, the LED Indicator will blink a set number of times corresponding to the event code that needs acknowledged.

Follow the **Pressure Relief Procedure**, page 22, before checking or repairing the equipment.

Check all possible problems and causes before disassembling equipment.

Troubleshoot LED Indicator Event Errors			
LED Indicator	Problem	Cause	Solution
Red, flashing, one flash	Motor or controller overheating.	Hot operating environment or hot operating conditions.	Turn the control knob (K) to the off (0) position. Keep the system connected to power and allow the equipment to cool before returning to operation.
			Inspect the fan. Repair or replace as needed. See your related motor manual. See Related Manuals , page 2.
Red, flashing, two flashes	Motor current error.	Special-case cause.	Turn the control knob down, then back up. If the problem persists, contact Technical Support.
Red, flashing, three flashes	Voltage error.	Input voltage is too high, too low, or too noisy.	Check line power voltage.
			Check control board connections. See your related motor manual. See Related Manuals , page 2.
Red, Flashing, four flashes	Motor sensor error.	Motor sensor disconnected.	Ensure the motor sensor cable is properly installed. See your related motor manual. See Related Manuals , page 2.
		Motor sensor not functioning.	Replace the motor sensor. See your related manuals. See your related motor manual. See Related Manuals , page 2.
Red, flashing, five flashes	Special-case problem.	Special-case cause.	Power cycle the unit. If the error persists, contact Technical Support.
Red, flashing, six flashes	Motor lead connection error.	One or more motor leads are connected incorrectly.	Check that all motor connections to the control board are correct.
Dim red, solid	Voltage detection error.	Power disconnected.	Check power connection.
		System powering down.	Allow equipment to finish shutdown.

Troubleshoot LED Indicator Event Errors			
LED Indicator	Problem	Cause	Solution
Yellow, flashing, continuous flash	Leak sensor alert.*	Leak detected in the equipment.	Check the diaphragm for rupture or incorrect installation. Repair or replace. Ensure that the diaphragm is torqued to specification.
		The leak sensor disconnected.	Ensure the leak sensor is properly installed. See your related leak sensor manual. See Related Manuals , page 2.
Green, flashing, continuous flash	Equipment stalled against pressure.	A valve downstream in the fluid line is closed or clogged.	Open the valve. Follow the Pressure Relief Procedure , page 22, and clear the valve.
		Special-case cause.	Be aware that the equipment is energized. Special-case action. See your related motor manual. See Related Manuals , page 2.
			Contact Technical Support.
No light (off)	Voltage detection error.	System not powered.	Check power connection.
		Control failure.	Check the branch circuit for proper voltage.
			Replace the control board. See your related motor manual. See Related Manuals , page 2.

* A leak sensor is not provided with the equipment. Accessory kits are available (purchase separately). See your related motor manual. See **Related Manuals**, page 2.

Maintenance

Establish a Preventive Maintenance Schedule

NOTICE

Regularly maintain the equipment to avoid pump damage due to spills, leaks, or diaphragm failure.

Establish a preventive maintenance schedule based on the equipment service history.

Inspect the Equipment

Regularly inspect the equipment for worn or damaged parts. Replace as needed.

Tighten Fasteners

Regularly check and torque all fasteners. Follow **Torque Fasteners**, page 39.

NOTICE

To avoid pump damage, do not over-torque the fasteners on the equipment.

Tighten Connections

Check and tighten all fluid connections before operating the equipment. Replace worn or damaged parts as needed.

NOTICE

Firmly tighten all connections to avoid leaks and damage to equipment parts.

Lubricate the Equipment

The equipment is lubricated at the factory. Re-lubricate the equipment when replacing diaphragms.

Lubricate the motor rotor when replacing diaphragms. See your related motor manual. See **Related Manuals**, page 2.

NOTICE

Do not over-lubricate the equipment. Lubricant exhaust could contaminate your fluid supply or other equipment. Excessive lubrication can also cause the equipment to malfunction.

Flush the Equipment

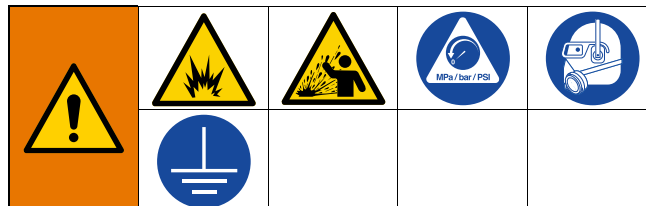

To avoid fire and explosion, always ground the equipment and waste container. To avoid static sparking and injury from splashing, always flush at the lowest possible pressure.

- Flush before fluid can dry or freeze in the equipment, at the end of the day, before storing, and before repairing equipment.
 - Flush at the lowest pressure possible. Check connections for leaks and tighten as needed.
 - Flush with a solvent that is compatible with the fluid being dispensed and the equipment wetted parts. Use a sanitary solution for hygienic applications.
 - Flushing schedule varies based on particular uses.
 - Always cycle the equipment during the entire flushing process.
1. Follow **Pressure Relief Procedure**, page 22.
 2. Insert the suction end of the fluid supply line (F) into a compatible solvent.
 3. Close the fluid drain valve (G).
 4. Ensure the control knob (K) is turned to off (O).
 5. If the fluid outlet line (J) has a dispensing device, place a metal part of the dispensing device to a grounded metal container and hold the dispensing valve open.
 6. Ensure all fluid shutoff valves (H) are open.
 7. Connect the equipment to a power source. See **Electrical Connections and Wiring**, starting on page 17.
 8. Slowly increase the control knob (K) until the equipment is operating at the set output level.
 9. Run the equipment for enough time to thoroughly clean the equipment and lines.
 10. Turn the control knob (K) to off (O).
 11. Follow **Pressure Relief Procedure**, page 22.

Store the Equipment



Always relieve the pressure and flush the equipment before storing the equipment for any length of time.

1. Follow **Pressure Relief Procedure**, page 22.
2. Follow **Flush the Equipment**, page 28.

NOTICE

Store the equipment at 0°C (32°F) or higher. Exposure to extreme low temperatures may result in damage to plastic parts.

NOTE: Thoroughly circulate the compatible solvent through the equipment and the system prior to use.

NOTICE

To avoid equipment damage, do not exceed a fluid inlet pressure of 103 kPa, 1 bar (15 psi) when cycling the equipment.

3. Follow **Pressure Relief Procedure**, page 22.

Troubleshooting

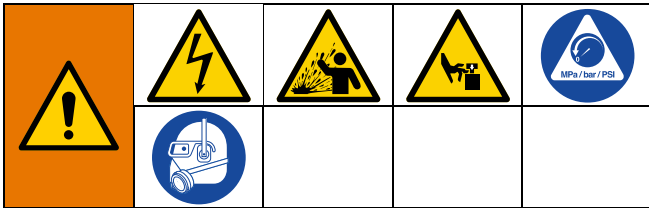



Follow the **Pressure Relief Procedure**, page 22, before checking or repairing the equipment.

Check all possible problems and causes before disassembling equipment.

Problem	Cause	Solution
Equipment emits beeping alert sound, LED light yellow	Pump starting automatic startup sequence. Pump is connected to a power source and the control knob (K) is not set to the off (0) position.	Turn the control knob (K) to the off (0) position or disconnect power to the system.
		If prepared to operate, allow the pump to complete the automatic startup sequence.
LED light flashing	Equipment error; special-case cause.	See Troubleshoot LED Indicator Event Errors , page 26.
Equipment cycles, but does not prime or pump (It is normal operation for auto-prime to run and then stop once the pump is primed).	Equipment running too fast, causing cavitation before prime.	Slow down the motor.
	Fluid not detected by the auto-prime sensor.	Ensure the suction end of the fluid supply line (F) is inserted into the fluid to be dispensed. Allow the auto-prime sequence to run for 30 seconds.
	Check is worn or wedged in the seat or manifold.	Replace check and seat.
	Worn seat.	Replace check and seat.
	Restricted outlet or inlet port.	Remove restriction.
	Loose inlet fittings or manifolds.	Tighten.
Equipment does not hold fluid pressure at stall	Damaged manifold seats.	Replace.
	Worn check, seats, or seals.	Replace.
	Loose manifold connections or fluid connections.	Tighten.
Equipment leaking fluid externally from joints [‡]	Loose diaphragm shaft fastener.	Tighten.
	Loose manifold connections or fluid cover connections.	Tighten.
	Worn manifold seats or seals.	Replace.







Problem	Cause	Solution
Equipment stalled, will not cycle	Fluid line clogged or valves closed.	Inspect; clear. Open valves downstream of the equipment.
	Motor or controller wired improperly.	Wire per instructions in your related motor manual. See Related Manuals , page 2.
	Leak sensor tripped.	Check diaphragm for rupture or incorrect installation. Repair or replace.
Reduced performance	Fluid line clogged.	Inspect; clear.
	Checks are sticky or leaking.	Clean or replace.
	Diaphragm (or backup diaphragm, if applicable) ruptured.	Replace.
Air bubbles in fluid	Fluid line is loose.	Tighten.
	Diaphragm (or backup diaphragm, if applicable) ruptured.	Replace.
	Loose manifolds.	Tighten manifold fasteners or clamps.
	Damaged seats or seals.	Replace seats or seals.
	Loose diaphragm shaft fastener.	Tighten.
Fluid leaking from lower ports on the equipment or fluid on the floor.	Loose diaphragm shaft fastener.	Tighten.
	Diaphragm rupture. Leak in the equipment.	Replace.
Equipment suddenly stops operating or shuts down.	Ground fault circuit interrupter (GFCI) tripped.	Remove controller from the GFCI circuit.
	Poor supply power.	Check connections. Determine and fix the source of the problem with the supply power.
	Exceeded operational parameters.	See Troubleshoot LED Indicator Event Errors , page 26, for event codes.
	Leak sensor* alert. Leak detected in the equipment.	Check the diaphragm for rupture or incorrect installation. Repair or replace.
	The leak sensor* disconnected.	Ensure the leak sensor is properly installed. See your related leak sensor manual.

* A leak sensor is not provided with the equipment. Accessory kits are available (purchase separately). See **Related Manuals**, page 2.

				
<p>‡ Do not modify or repair explosion proof joints. Modifying explosion proof joints will invalidate the Hazardous Location Certification of the equipment and may produce an explosion hazard.</p>				

Repair

NOTE: Repair kits are available (purchase separately).



				
				

This equipment stays pressurized until pressure is manually relieved. To help prevent serious injury from pressurized fluid, such as splashing fluid and moving parts, follow **Pressure Relief Procedure** when you stop operating and before cleaning, checking, or servicing the equipment.



To avoid severe burns, do not touch hot fluid or hot equipment.

Follow **Prepare Equipment for Repair**, page 32, before performing any service or repair to the equipment.

Prepare Equipment for Repair

				
---	---	---	--	--

To avoid injury from fire, explosion, or electric shock, all electrical wiring must be done by a qualified electrician and comply with all local codes and regulations.

				
---	---	--	--	--

Models in Explosive Atmospheres or Hazardous (Classified) Locations: To avoid injury from fire and explosion, move the equipment to a non-explosive or non-hazardous location before performing any service or repair to the equipment.

Always complete the following procedure before performing any service or repair to the equipment.

1. Follow **Pressure Relief Procedure**, page 22.
2. Follow **Flush the Equipment**, page 28.
3. Verify that the equipment is turned off and power to the system is disconnected before performing any service or repair procedure.

4. Disconnect all fluid lines.
5. Optional: Mount the back of the pump (opposite side from the motor) to the maintenance bracket stand (purchase separately). This positions the pump facing up, enabling easy working access to the pump and motor. The stand can be mounted to a workbench through the mounting holes on the feet. See FIG. 13.
 - a. Loosen the four bolts that hold the logo plate (if present) to the pump.
 - b. Slide the bracket stand behind the bolts.
 - c. Tighten the bolts.
 - d. After repairing the pump, remove the pump from the bracket stand and return it to service.

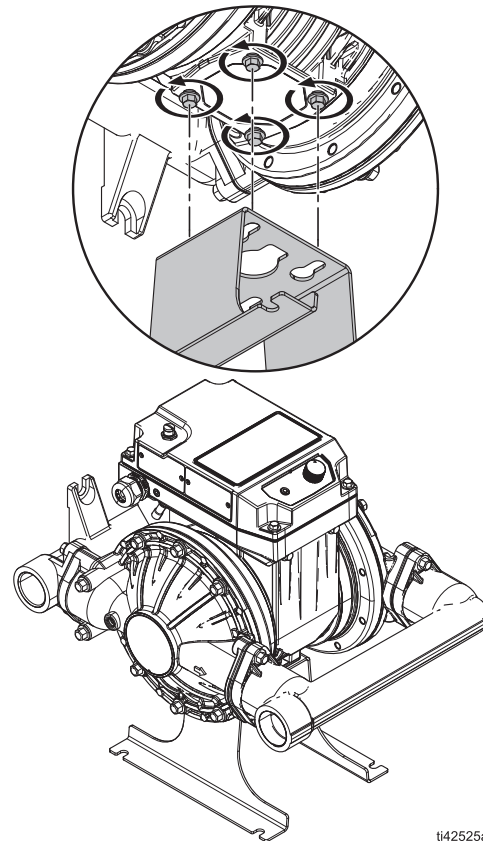

ti42525a

FIG. 13. Maintenance bracket stand

Repair the Check Valves

Required Tools:

- 10 mm socket wrench (for all VA-2E25 models, VA-2E40 plastic models, and VA-2E50 plastic models)
- 13 mm socket wrench (for VA-2E40 metal models and VA-2E50 metal models)

See FIG. 14.

Disassemble Check Valves



1. Follow **Prepare Equipment for Repair**, page 32.
2. Drain the equipment.
NOTE: After draining, rotate the equipment to positions which will aid disassembly.
3. On the outlet manifold (4), remove all fasteners (6).
4. Remove the outlet manifold (4), seals (10, if applicable), guides (9b, if applicable), checks (9), and seats (8).

NOTE: Use care while removing manifolds to avoid damage to check valve components.

5. On the inlet manifold (5), remove all fasteners (6, 6b, if applicable).
6. Remove the inlet manifold (5), seals (10, if applicable), guides (9b, if applicable), checks (9), and seats (8).

NOTE: Use care while removing manifolds to avoid damage to check valve components.

7. Clean and inspect parts for wear or damage. Replace as needed.

Reassemble Check Valves

1. Align and place seats (8), checks (9), guides (9b, if applicable), seals (10, if applicable), and manifolds (4, 5), exactly as shown for your equipment model. See your related parts manual. See **Related Manuals**, page 2.
2. Use the fasteners (6, 6b, if applicable) to loosely attach the manifolds (4, 5) to the fluid covers (3). After all components are properly aligned, torque the fasteners (6, 6b, if applicable) on the manifolds (4, 5). See **Torque Fasteners**, page 39.

 See **Torque Fasteners**, page 39.

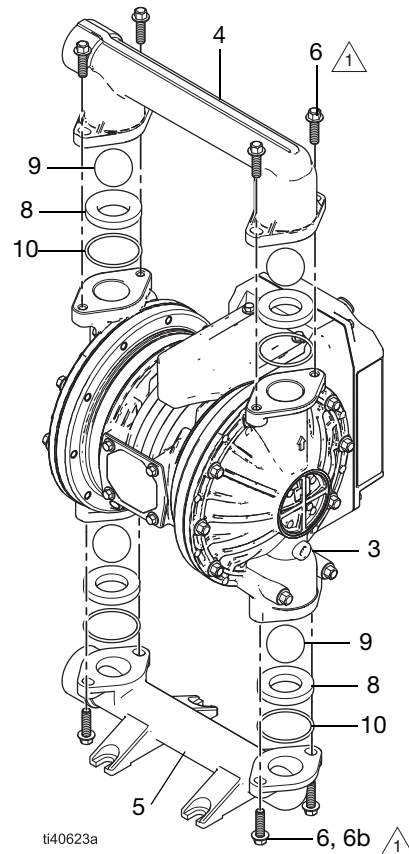

FIG. 14: Check Valves

Repair the Standard Diaphragms

Required Tools:

- 10 mm socket wrench (for all VA-2E25 models, VA-2E40 plastic models, and VA-2E50 plastic models)
- 13 mm socket wrench (for VA-2E40 metal models and VA-2E50 metal models)
- Torque wrench
- 25 mm open-end wrench
- Lubriplate® Synxtreme HD-2 grease, part number 814-0347 (or equivalent NLGI Grade 2 synthetic grease with calcium sulfonate base)
- 15 mm hex wrench

See FIG. 15–FIG. 17.

NOTE: Lubricate the motor rotor when replacing diaphragms. See your related motor manual. See **Related Manuals**, page 2.

Disassemble the Standard Diaphragms



To avoid severe burns, do not touch hot fluid or hot equipment.

1. Follow **Prepare Equipment for Repair**, page 32.
2. Follow **Disassemble Check Valves**, page 33.
3. Remove all fasteners (7, 7b, if applicable) from the fluid covers (3). Remove the fluid covers (3).
4. Use an applicable wrench to firmly hold one diaphragm fastener (15) in place. At the same time, use an applicable wrench to loosen the fastener (15) on the opposite side.
5. Remove the fastener (15), seal (16, if applicable), fluid plate (11), diaphragm (13), and diaphragm backer (14) from the shaft (1a) on the side of the pump with the loosened fastener (15).
6. Loosen the remaining diaphragm fastener (15).

If the first loosened diaphragm fastener (15) is on the side of the shaft (1a) with the wrench flat:

- a. Use an applicable wrench to firmly hold the flat of the shaft (1a) in place. At the same time, use

an applicable wrench to loosen the remaining diaphragm fastener (15). See FIG. 17.

If the first loosened diaphragm fastener (15) is opposite the wrench flat on the shaft (1a):

- a. Follow the procedure to lubricate the rotor in your related motor manual to access the flat of the shaft (1a). See **Related Manuals**, page 2.
 - b. After the flat of the shaft (1a) is accessible, use an applicable wrench to firmly hold the flat of the shaft (1a) in place. At the same time, use an applicable wrench to loosen the remaining diaphragm fastener (15). See FIG. 17.
7. Remove the remaining fastener (15), seal (16, if applicable), fluid plate (11), diaphragm (13), and diaphragm backer (14), and air-side plate (21) from the shaft (1a).

NOTE: Do not remove the diaphragm shaft (1a) from the motor (1).

NOTICE

To avoid damage to the rotor or equipment, do not remove the shaft (1a) from the motor (1). Removing the shaft will cause the rotor balls to dislodge from the rotor and the rotor will not function properly.

8. Clean and inspect parts for wear or damage. Replace parts as needed.
9. Lubricate the rotor. See your related motor manual. See **Related Manuals**, page 2.

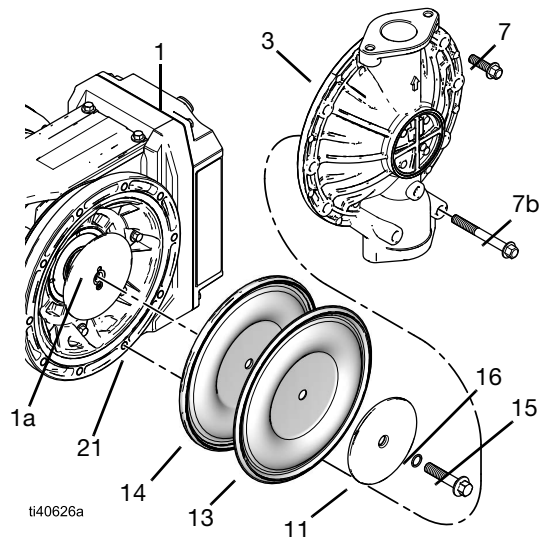

FIG. 15: Standard Diaphragms

Reassemble the Standard Diaphragms

NOTICE

After reassembly, allow the thread locker to cure for 12 hours, or per instructions of the manufacturer, prior to operating the equipment. The equipment will be damaged if the diaphragm shaft fastener loosens.

1. Assemble the air-side plate (21), diaphragm backers (14), diaphragms (13), fluid side plates (11), and seals (16, if applicable) with the fasteners (15) exactly as shown for your equipment model. See your related parts manual. See **Related Manuals**, page 2.

NOTE: Face the rounded side of the fluid side plate (11) toward the diaphragm (13).

NOTE: Regardless of any markings on the diaphragm backer (14), always assemble the diaphragm backer (14) so that the outer bead cups around (not away from) the outer bead of the diaphragm (13).

NOTE: Apply thread locker to the fastener (15) for all diaphragm assemblies.

1. Apply a medium-strength thread locker to the shaft side of the fastener to attach the diaphragm to the shaft.
2. Rounded side faces toward the diaphragm (13).

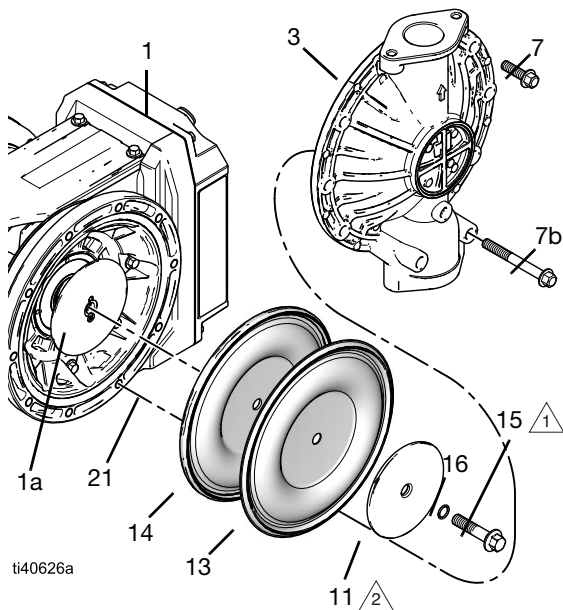
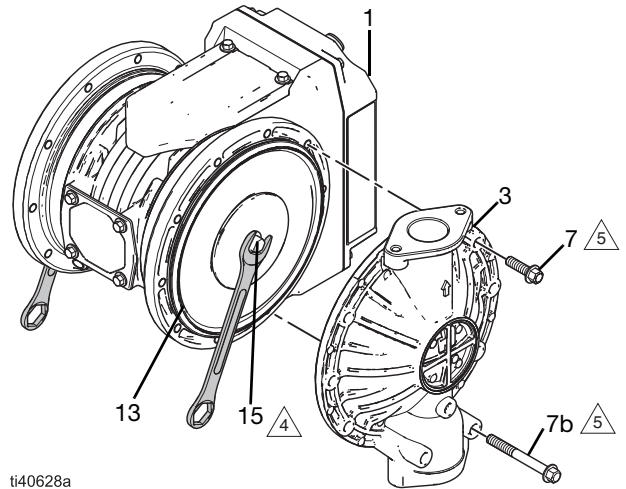

Fig. 16: Reassemble Standard Diaphragms

2. Install the assembled diaphragm assemblies into the shaft (1a) and hand-tighten the fasteners (15).
3. Use an applicable wrench to firmly hold one fastener (15) in place. At the same time, use an applicable wrench to torque the opposite fastener (15) to 68 N•m (50 ft-lb). See FIG. 17.

4. Torque to 50 ft-lb (68 N•m).

5. See **Torque Fasteners**, page 39.



ti40628a

Fig. 17: Tighten Standard Diaphragms

4. Rotate the shaft of the motor to center it in the motor, so that neither diaphragm is extended away from the housing, which could inhibit installing the fluid covers.

NOTE: If it is not possible for both diaphragms to be in contact with the housing, choose one diaphragm to position first. Once the first fluid cover is fastened, slowly drive the motor so that the other diaphragm is in contact with the housing. Then fasten the second fluid cover.

5. Align the fluid covers (3) to the motor (1).
6. Install fasteners (7, 7b, if applicable) to hold the fluid covers (3) in place.

NOTE: To ensure proper spacing and alignment of the manifolds (4, 5), install fasteners (7, 7b, if applicable) loose enough to allow for fluid cover movement before securing the fluid covers (3) in place.

7. Torque all fasteners (7, 7b, if applicable). Follow **Torque Fasteners**, page 39.
8. Reassemble the check valves and manifolds as explained in **Reassemble Check Valves**, page 33.

Repair the Overmolded Diaphragms

Required Tools:

- 10 mm socket wrench (for all VA-2E25 models, VA-2E40 plastic models, and VA-2E50 plastic models)
- 13 mm socket wrench (for VA-2E40 metal models and VA-2E50 metal models)
- Torque wrench
- 25 mm open-end wrench
- Lubriplate® Synxtreme HD-2 grease, part number 814-0347 (or equivalent NLGI Grade 2 synthetic grease with calcium sulfonate base)

See FIG. 18–FIG. 20.

NOTE: Lubricate the motor rotor when replacing diaphragms. See your related motor manual. See **Related Manuals**, page 2.

Disassemble the Overmolded Diaphragms



1. Follow **Prepare Equipment for Repair**, page 32.
2. Follow **Disassemble Check Valves**, page 33.
3. Remove all fasteners (7, 7b, if applicable) from the fluid covers (3). Remove the fluid covers (3).
4. Firmly grip the outer edge of a diaphragm (13) to hold in place. At the same time, securely grip the outer edge of the opposite diaphragm (13) and rotate counterclockwise to loosen. Remove the diaphragm (13).

NOTE: If needed, leave one fluid cover fastened. With one diaphragm exposed, use both hands to loosen the exposed diaphragm.

NOTE: Do not remove the diaphragm shaft (1a) from the motor (1).

NOTICE

To avoid damage to the rotor or equipment, do not remove the shaft (1a) from the motor (1). Removing the shaft will cause the rotor balls to dislodge from the rotor and the rotor will not function properly.

5. Remove the remaining diaphragm (13).

If the first loosened diaphragm (13) is on the side of the shaft (1a) with the wrench flat:

- a. Use an applicable wrench to firmly hold the flat of the shaft (1a) in place. At the same time, securely grip the outer edge of the opposite diaphragm (13) and rotate counterclockwise to loosen.

If the first loosened diaphragm (13) is opposite the wrench flat on the shaft (1a):

- a. Follow the procedure to lubricate the rotor in your related motor manual to access the flat of the shaft (1a). See **Related Manuals**, page 2.
- b. After the flat of the shaft (1a) is accessible, use an applicable wrench to firmly hold the flat of the shaft (1a) in place. At the same time, securely grip the outer edge of the opposite diaphragm (13) and rotate counterclockwise to loosen.

6. Clean and inspect parts for wear or damage. Replace parts as needed.
7. Lubricate the rotor. See your related motor manual. See **Related Manuals**, page 2.

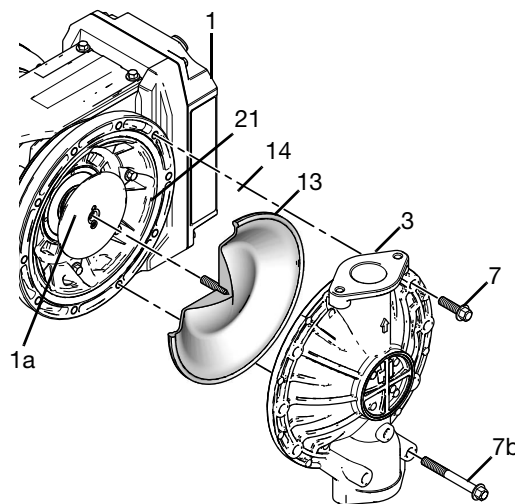

ti40627a

FIG. 18: Overmolded Diaphragms

Reassemble the Overmolded Diaphragms

NOTICE

After reassembly, allow the thread locker to cure for 12 hours, or per instructions of the manufacturer, prior to operating the equipment. The equipment will be damaged if the diaphragm shaft fastener loosens.

1. On the side of the shaft (1a) opposite of the wrench flat, install the air-side plate (21), diaphragm backer (14), and diaphragm assembly (13, 15) into the shaft (1a). Firmly tighten.

NOTE: Regardless of any markings on the diaphragm backer (14), always assemble the diaphragm backer (14) so that the outer bead cups around (not away from) the outer bead of the diaphragm (13).

NOTE: Apply thread locker to the fastener (15) for all diaphragm assemblies.

1. Apply a medium-strength thread locker to the shaft side of the fastener to attach the diaphragm to the shaft.

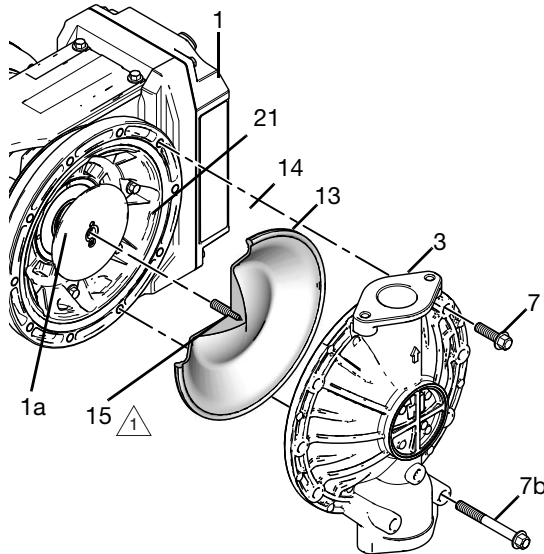

ti40627a

FIG. 19: Reassemble Overmolded Diaphragms

2. Use an applicable wrench to hold flat of the shaft (1a) firmly in place. At the same time, grip the diaphragm (13) securely around the outer edge and rotate clockwise to firmly tighten.
3. Rotate the shaft (1a) until it is centered in the motor (1).
4. On the side of the equipment with the installed diaphragm, align the fluid cover (3) to the motor (1).

5. Loosely install the fasteners (7, 7b, if applicable) to hold the fluid cover (3) in place.
6. On the side of the shaft (1a) with the wrench flat, install the air-side plate (21), diaphragm backer (14), and diaphragm assembly (13, 15) into the shaft (1a). Firmly tighten.
7. Align the fluid cover (3) to the motor (1).
8. Loosely install the fasteners (7, 7b, if applicable) to hold the fluid cover (3) in place.

NOTE: To ensure proper spacing and alignment of the manifolds (4, 5), install fasteners (7, 7b, if applicable) loose enough to allow for fluid cover movement before securing the fluid covers (3) in place.

9. Torque all fasteners (7, 7b, if applicable). Follow **Torque Fasteners**, page 39.
10. Reassemble the check valves and manifolds as explained in **Reassemble Check Valves**, page 33.

5. See **Torque Fasteners**, page 39.

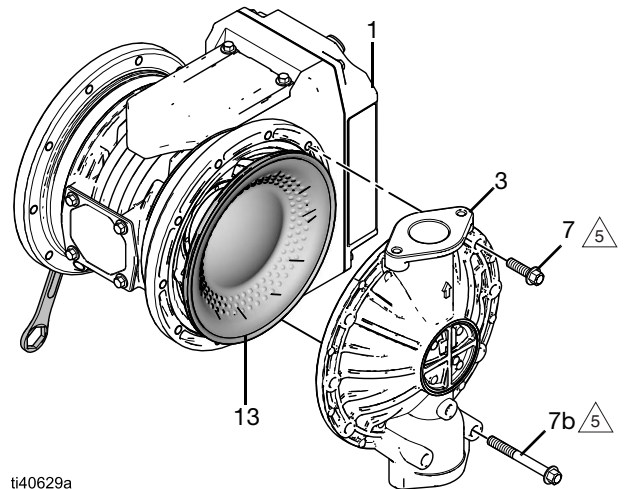

ti40629a

FIG. 20: Tighten Overmolded Diaphragms

Recycling and Disposal

End of Equipment Life

At the end of the useful life of the equipment, disassemble and recycle the equipment in a responsible manner.

- Follow **Pressure Relief Procedure**, page 22.
- Drain and dispose of fluids according to applicable regulations. See the Safety Data Sheet (SDS) of the material manufacturer.
- Remove motors, circuit boards, LCDs (liquid crystal displays), and other electronic components. Recycle according to applicable regulations.
- Do not dispose of electronic components with household or commercial waste.



- Deliver remaining equipment to a recycling facility.

Torque Fasteners

Torque Instructions

To ensure proper sealing, torque fasteners using the following procedure.

1. Start all fasteners a few turns.
2. Follow the torque sequence to turn down each fastener until each fastener is slightly under the specified torque. See **Torque Sequence**, page 39.
3. Follow the torque sequence to turn each fastener by 1/2 turn or less until each fastener is at the specified torque. See **Torque Sequence**, page 39.

Torque Sequence

Fully torque all fasteners (7, 7b, if applicable) on the fluid covers (3) before torquing the fasteners (6, 6b, if applicable) on the manifolds (4, 5).

Follow **Torque Instructions**, page 39.

NOTICE

To avoid pump damage, do not over-torque the fasteners on the equipment.

Torque Sequence for VA-2E25 Models

Fluid Covers (3)

Torque fasteners (7, 7b, if applicable) to 12 N•m (110 in-lb).

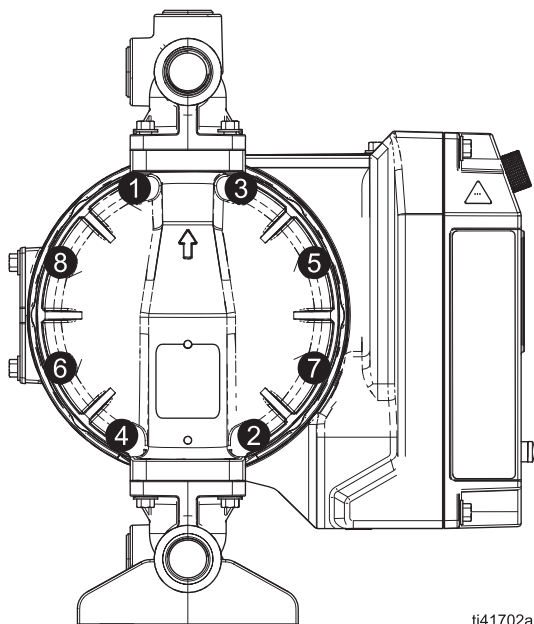

ti41702a

Manifolds (4, 5)

Torque fasteners (6, 6b, if applicable) to 11 N•m (100 in-lb).

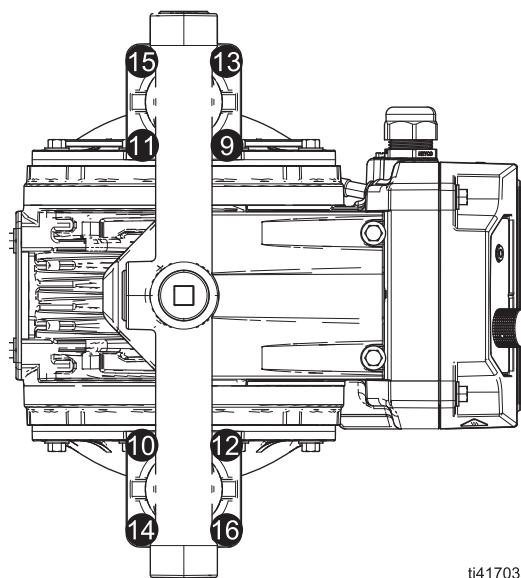

ti41703a

Torque Sequence for VA-2E40 Models

Fluid Covers (3)

Torque fasteners (7, 7b, if applicable) to 21–25 N•m (190–220 in-lb).

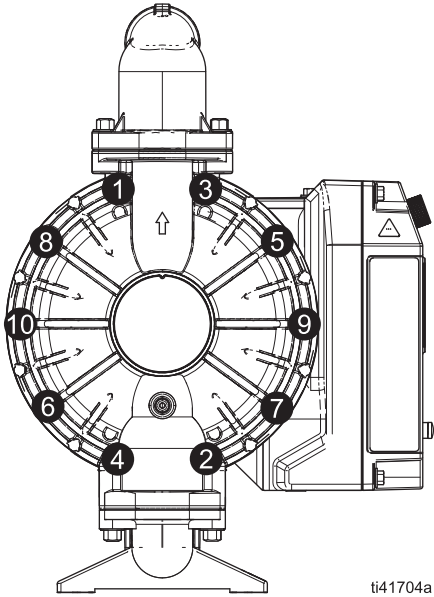

ti41704a

Manifolds (4, 5)

For VA-2E40 plastic models: Torque fasteners (6, 6b, if applicable) to 9–10 N•m (80–90 in-lb).

For VA-2E40 metal models: Torque fasteners (6, 6b, if applicable) to 14–17 N•m (120–150 in-lb).

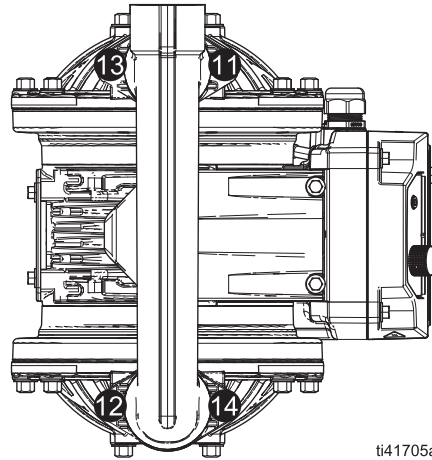

ti41705a

Torque Sequence for VA-2E50 Models

Fluid Covers (3)	Manifolds (4, 5)
<p>Torque fasteners (7, 7b, if applicable) to 21–25 N•m (190–220 in-lb).</p>	<p>For VA-2E50 plastic models: Torque fasteners (6, 6b, if applicable) to 17–18 N•m (150–160 in-lb).</p> <p>For VA-2E50 aluminum models: Torque fasteners (6, 6b, if applicable) to 14–17 N•m (120–150 in-lb).</p> <p>For VA-2E50 metal models, except aluminum: Torque fasteners (6, 6b, if applicable) to 21–25 N•m (190–220 in-lb).</p>

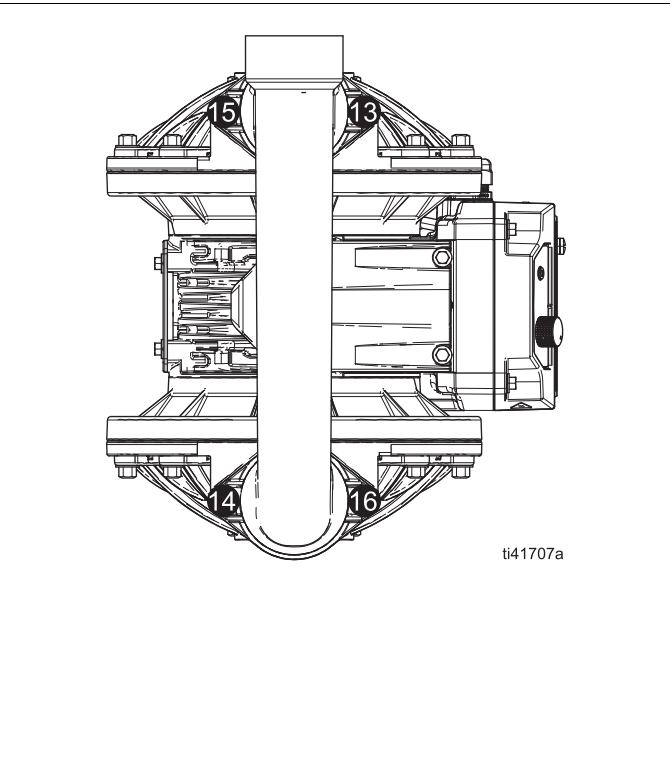
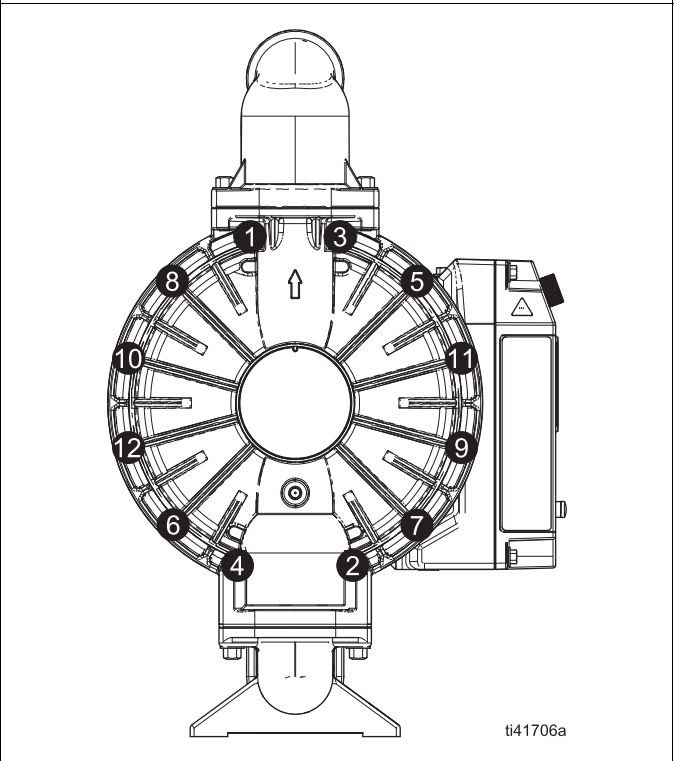

Performance Charts

Performance may vary based on pump materials, suction condition, discharge pressure, and fluid type.

Performance Chart for VA-2E25 Models

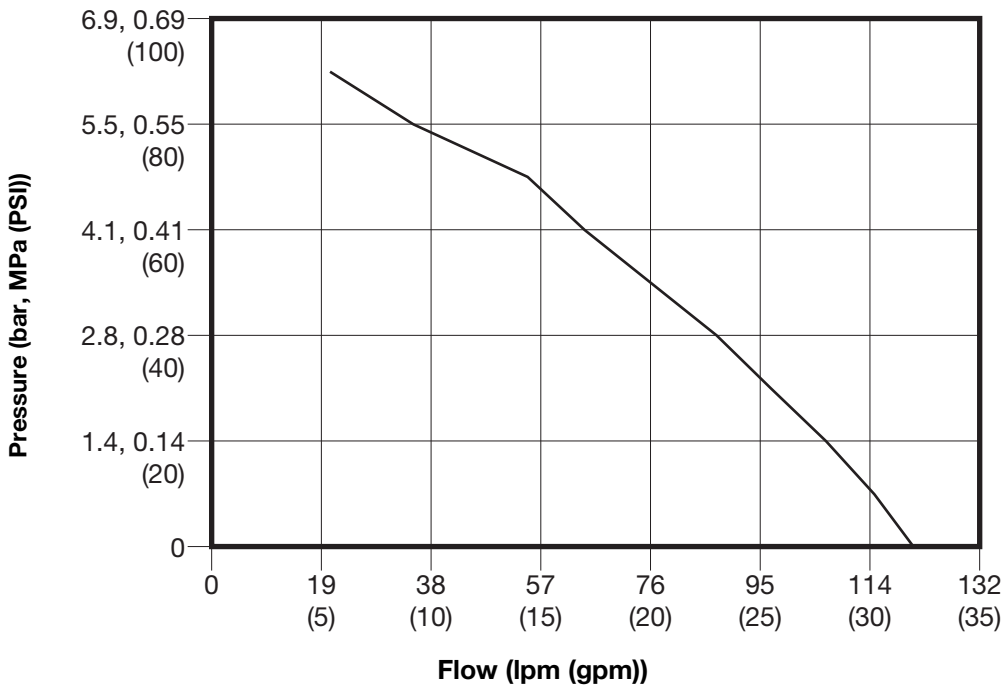

Performance Chart for VA-2E40 Models

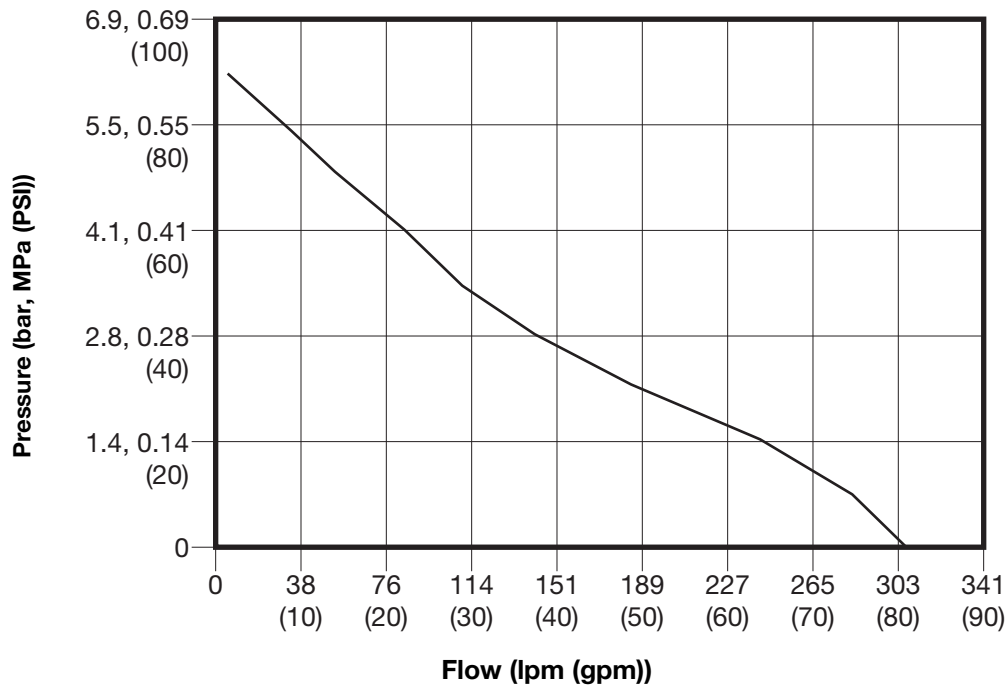

Performance Chart for VA-2E50 Models

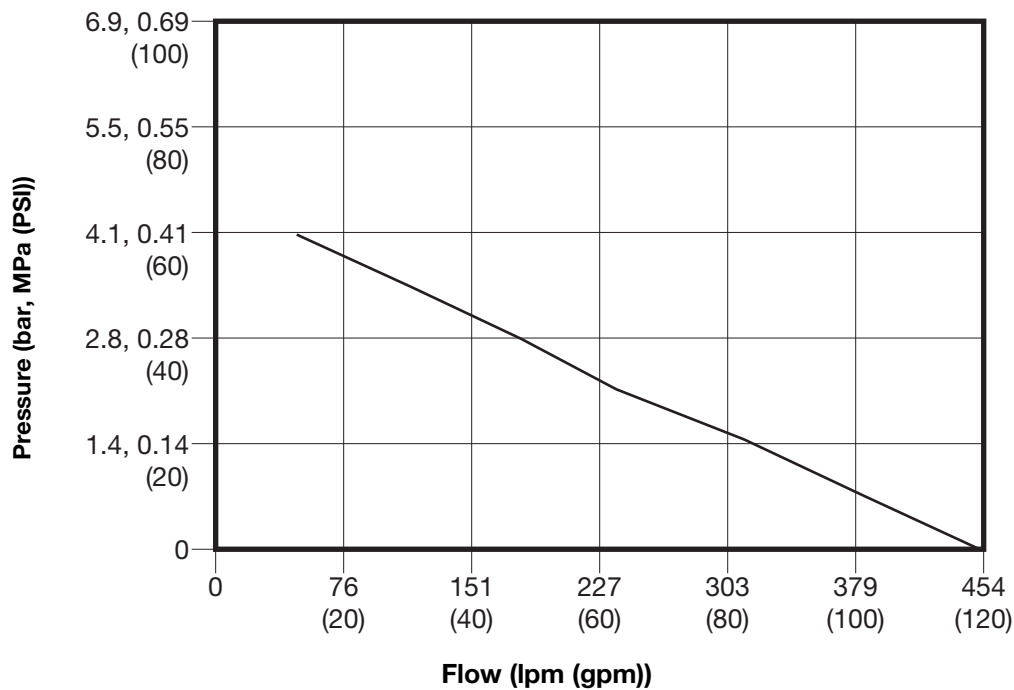

Dimensions

Dimensions for VA-2E25 Models

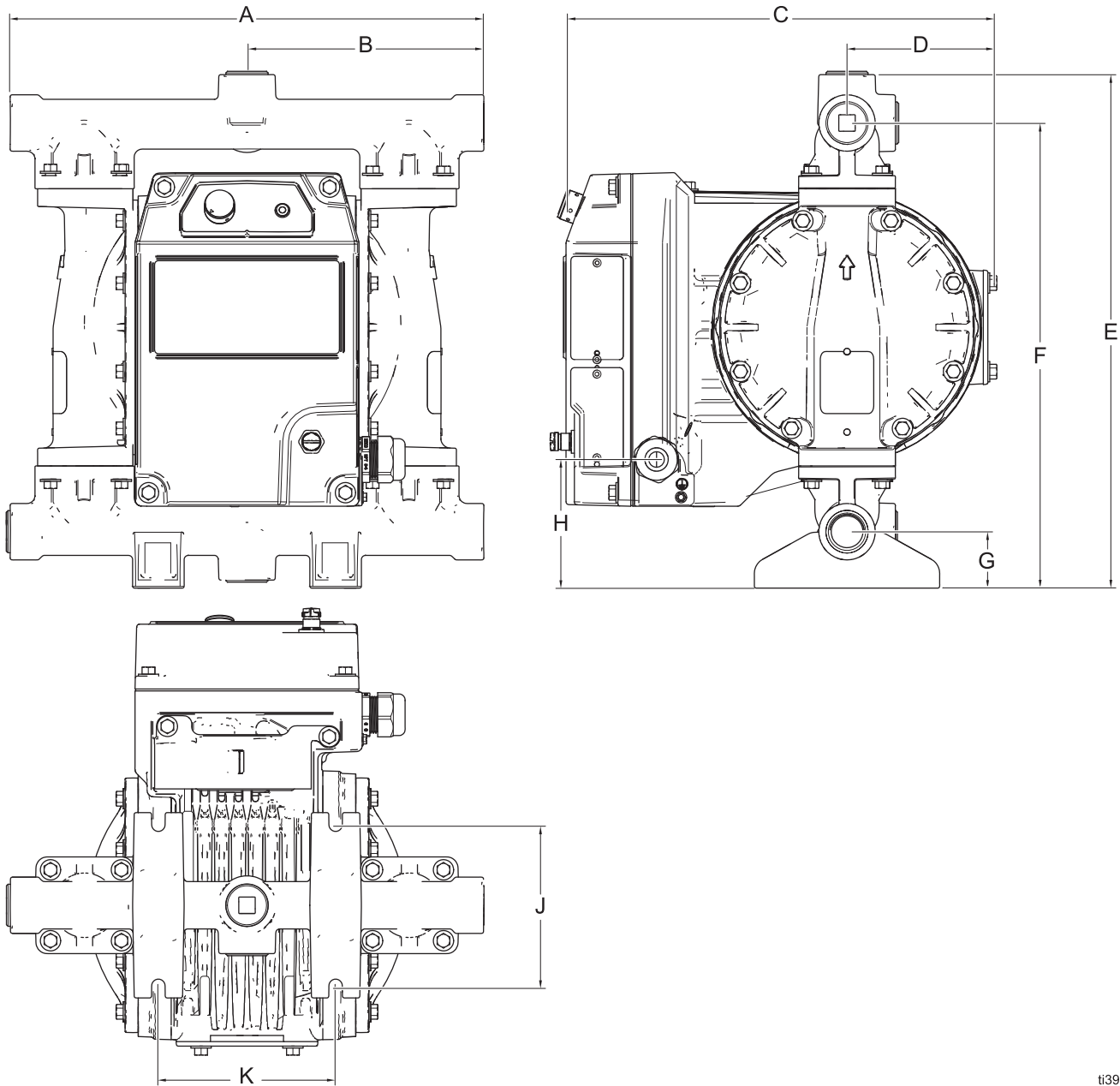

ti39017e

FIG. 21: VA-2E25 Model Dimensions

VA-2E25 Model Dimensions						
Ref.	Wetted Section Material					
	A		S		P, K	
	cm	in.	cm	in.	cm	in.
A	37.34	14.70	35.31	13.90	38.61	15.20
B	18.67	7.35	16.71	6.58	20.32	8.00
C	33.66	13.25	33.66	13.25	33.66	13.25
D	11.61	4.57	11.61	4.57	11.61	4.57
E	40.49	15.94	34.80	13.70	45.21	17.80
F	36.68	14.44	32.77	12.90	39.88	15.70
G	4.47	1.76	2.79	1.10	6.35	2.50
H	9.40	3.70	5.59	2.20	11.91	4.69
J	12.70	5.00	12.70	5.00	12.70	5.00
K	13.97	5.50	13.97	5.50	26.47	10.42

Dimensions for VA-2E40 Models

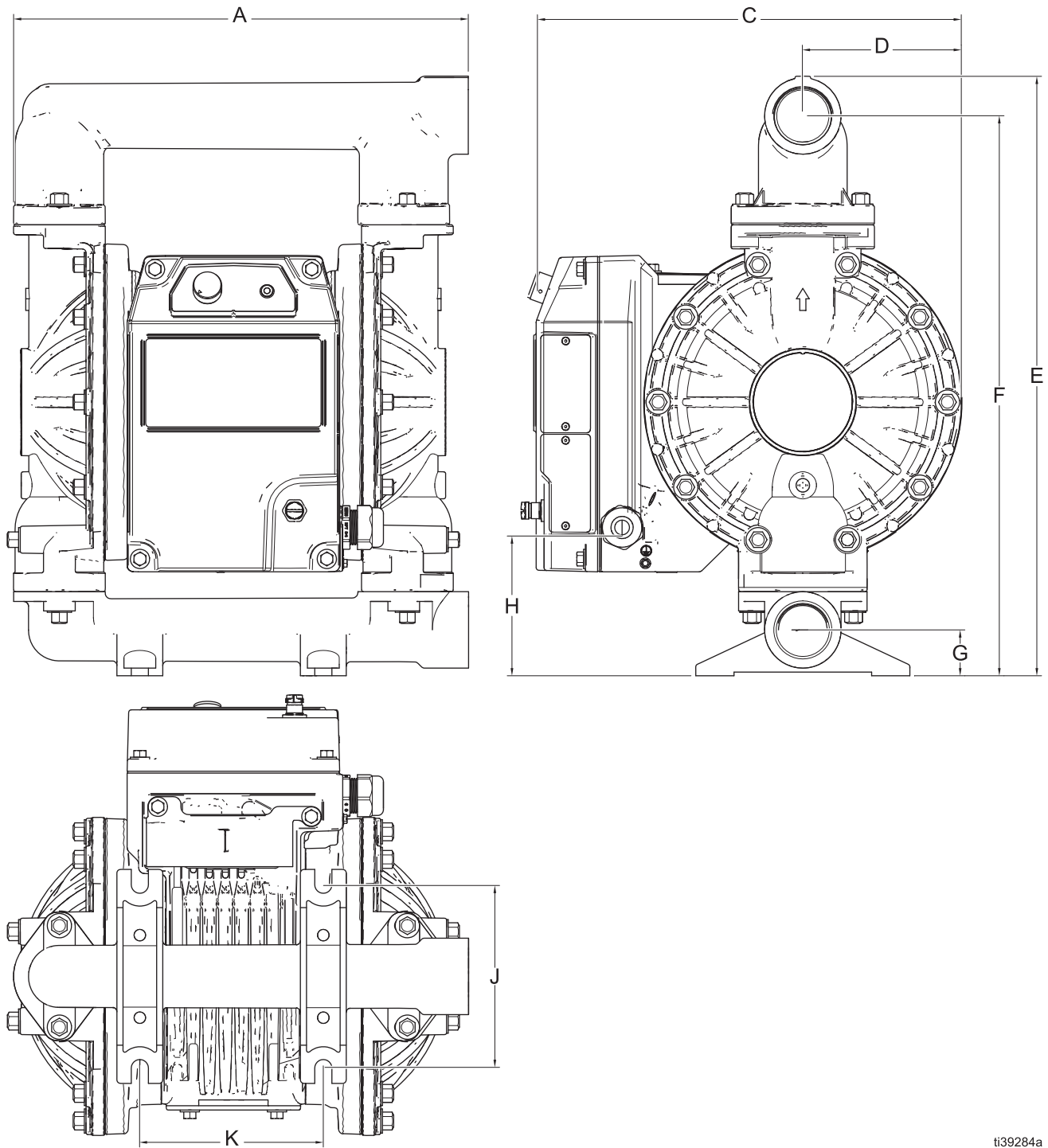

ti39284a

FIG. 22: VA-2E40 Model Dimensions

VA-2E40 Model Dimensions						
Ref.	Wetted Section Material					
	A		S		P, K	
	cm	in.	cm	in.	cm	in.
A	38.28	15.07	40.89	16.10	44.70	17.60
C	35.08	13.81	35.18	13.85	35.23	13.87
D	13.13	5.17	13.23	5.21	13.28	5.23
E	49.78	19.60	48.18	18.97	55.88	22.00
F	46.48	18.30	45.09	17.75	49.02	19.30
G	3.81	1.50	3.66	1.44	7.62	3.00
H	11.56	4.55	11.56	4.55	14.86	5.85
J	15.24	6.00	15.24	6.00	15.24	6.00
K	15.24	6.00	15.24	6.00	15.24	6.00

Dimensions for VA-2E50 Models

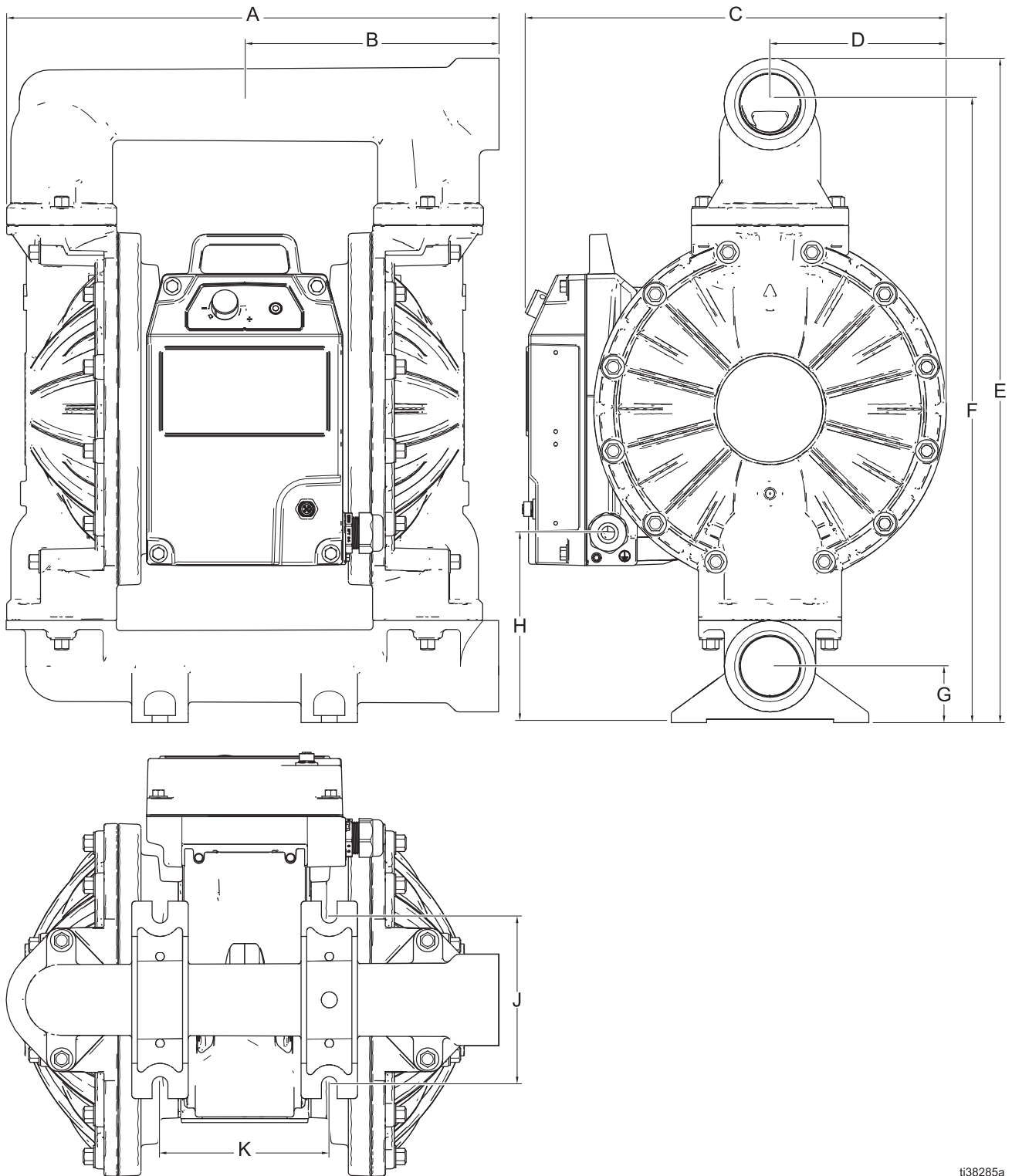

ti38285a

FIG. 23: VA-2E50 Model Dimensions

VA-2E50 Model Dimensions						
Ref.	Wetted Section Material					
	A		I, S		C, P, K	
	cm	in.	cm	in.	cm	in.
A	44.45	17.50	46.05	18.13	50.04	19.70
B	22.86	9.00	23.88	9.40	27.94	11.00
C	37.82	14.89	37.82	14.89	37.82	14.89
D	15.88	6.25	15.88	6.25	15.88	6.25
E	59.94	23.60	66.90	26.34	65.28	25.70
F	55.63	21.90	62.97	24.79	57.66	22.70
G	5.08	2.00	6.35	2.50	8.89	3.50
H	17.07	6.72	22.89	9.01	19.13	7.53
J	15.24	6.00	15.24	6.00	15.24	6.00
K	15.24	6.00	16.51	6.50	15.24	6.00

Technical Specifications

Fluid Temperature Range

NOTICE

Temperature limits are based on mechanical stress only. Certain chemicals will further limit the fluid temperature range. Stay within the temperature range of the most-restricted wetted component. Operating at a fluid temperature that is too high or too low for the components of your pump may cause equipment damage.

NOTE: The maximum fluid temperature for Hazardous units should not exceed 110°C (230°F) or the limitation based on the Wetted Section Materials, whichever is lower.

Material of Wetted Contact Section Parts (Seat, Check, Diaphragm)*	Fluid Temperature Range by Wetted Section Material					
	Metal (A, I, S)*		Plastic (K)*		Plastic (C, P)*	
	Celsius	Fahrenheit	Celsius	Fahrenheit	Celsius	Fahrenheit
AC	-29° to 82°	-20° to 180°				
AL	-51° to 135°	-60° to 275°				
BN	-12° to 82°	10° to 180°				
NO	-12° to 82°	10° to 180°				
NE	-12° to 82°	10° to 180°				
NW	-12° to 82°	10° to 180°				
VT	-40° to 135°	-40° to 275°				
GE	-40° to 82°	-40° to 180°				
TO	-40° to 82°	-40° to 180°				
HY	-29° to 66°	-20° to 150°				
PP	0° to 79°	32° to 175°	0° to 66°	32° to 150°		
TS	-40° to 82°	-40° to 180°				
TF	-40° to 104°	-40° to 220°				
KY	-12° to 107°	10° to 225°				
HS	-40° to 104°	-40° to 220°				
SP	-40° to 82°	-40° to 180°				
SS	-51° to 135°	-60° to 275°				

* See **Configuration Matrix**, starting on page 7, for detailed descriptions.

Technical Specifications for VA-2E25 Models

VERDERAIR VA-2E25 Pumps		
	Metric	US
Maximum fluid working pressure	6.89 bar, 0.69 MPa	100 psi
Maximum free-flow delivery	114 lpm	30 gpm
Maximum size pumpable solids	3.2 mm	0.125 in.
Environmental temperature range	-20° to 40°C	-4° to 104°F
Maximum operating altitude	3000 m	9842 ft
Electrical ratings		

VERDERAIR VA-2E25 Pumps				
	Metric		US	
	Rated Voltage	Phase	Hertz	Current
VA-2E25 models, D1 motor	200–240 V	3	50/60 Hz	7.5 A
VA-2E25 models, D2 motor	200–240 V	1	50/60 Hz	10 A
VA-2E25 models, D3 motor	200–240 V	3	50/60 Hz	7.5 A
VA-2E25 models, D4 motor	200–240 V	1	50/60 Hz	10 A
VA-2E25 models, D5 motor	100–120 V	1	50/60 Hz	12 A
VA-2E25 models, D6 motor	100–120 V	1	50/60 Hz	12 A
Materials of construction				
See Configuration Matrix on page 7 for materials of construction for your equipment model.				
Fluid inlet/outlet sizes				
Models with wetted section materials coded:				
	A, S, H	1 in. npt(f) or 1 in. bspt		
	C, P, K	DIN PN10 025–1 in. ANSI 150 1 NPS		
Maximum suction lift*				
	Wet	8.8 m	29.0 ft	
	Dry	2.4 m	7.9 ft	
Noise (dBa)				
Maximum sound pressure		74 dBa at full power and flow		
<i>Sound pressure measured 1.6 feet (0.5 meter) from equipment.</i>				
<i>Sound power measured per ISO-9614-2.</i>				
Weight				
Models with wetted section materials coded:				
	A	28.1 kg	62 lb	
	S	35.8 kg	79 lb	
	H	35.8 kg	79 lb	
	C, P	27.7 kg	61 lb	
	K	30.4 kg	67 lb	
Notes				
<i>*May vary based on pump materials, suction condition, discharge head, pressure, and fluid type.</i>				
<i>All trademarks or registered trademarks are the property of their respective owners.</i>				

Technical Specifications for VA-2E40 Models

VERDERAIR VA-2E40 Pumps				
	Metric		US	
Maximum fluid working pressure	6.89 bar, 0.69 MPa		100 psi	
Maximum free-flow delivery	303 lpm		80 gpm	
Maximum size pumpable solids	4.8 mm		0.19 in.	
Environmental temperature range	-20° to 40°C		-4° to 104°F	
Maximum operating altitude	3000 m		9842 ft	
Electrical ratings				
	Rated Voltage	Phase	Hertz	Current
VA-2E40 models, D1 motor	200–240 V	3	50/60 Hz	7.5 A
VA-2E40 models, D2 motor	200–240 V	1	50/60 Hz	15 A
VA-2E40 models, D3 motor	200–240 V	3	50/60 Hz	7.5 A
VA-2E40 models, D4 motor	200–240 V	1	50/60 Hz	15 A
Materials of construction				
See Configuration Matrix on page 7 for materials of construction for your equipment model.				
Fluid inlet/outlet sizes				
Models with wetted section materials coded:				
	A, S	1.5 in. npt(f) or 1.5 in. bspt		
	C, P, K	DIN PN10 040–1-1/2 in. ANSI 150 1-1/2 NPS		
Maximum suction lift*				
	Wet	5.48 m	18.0 ft	
	Dry	5.2 m	17.0 ft	
Noise (dBa)				
Maximum sound pressure	74 dBa at full power and full flow			
<i>Sound pressure measured 1.6 feet (0.5 meter) from equipment.</i>				
<i>Sound power measured per ISO-9614-2.</i>				
Weight				
Models with wetted section materials coded:				
	A	32.2 kg	71 lb	
	S	50.8 kg	112 lb	
	C, P	34.0 kg	75 lb	
	K	38.5 kg	85 lb	
Notes				
*May vary based on pump materials, suction condition, discharge head, pressure, and fluid type.				
All trademarks or registered trademarks are the property of their respective owners.				

Technical Specifications for VA-2E50 Models

VERDERAIR VA-2E50 Pumps				
	Metric		US	
Maximum fluid working pressure	4.1 bar, 0.41 MPa		60 psi	
Maximum free-flow delivery	454 lpm		120 gpm	
Maximum size pumpable solids	6.35 mm		0.25 in.	
Environmental temperature range	-20° to 40°C		-4° to 104°F	
Maximum operating altitude	3000 m		9842 ft	
Electrical ratings				
	Rated Voltage	Phase	Hertz	Current
VA-2E50 models, D1 motor	200-240 V	3	50/60 Hz	7.5 A
VA-2E50 models, D2 motor	200-240 V	1	50/60 Hz	15 A
VA-2E50 models, D3 motor	200-240 V	3	50/60 Hz	7.5 A
VA-2E50 models, D4 motor	200-240 V	1	50/60 Hz	15 A
Materials of construction				
See Configuration Matrix on page 7 for materials of construction for your equipment model.				
Fluid inlet/outlet sizes				
Inlet/Outlet size for models with wetted section materials coded:				
A, I, S		2 in. npt(f) or 2 in. bspt		
C, P, K		DIN PN16 050—2 in. ANSI 150 2 NPS JIS 10K 50		
Maximum suction lift*				
	Wet	5.48 m	18.0 ft	
	Dry	4.8 m	15.9 ft	
Noise (dBa)				
Maximum sound pressure		77 dBa at full power and full flow		
<i>Sound pressure measured 1.6 feet (0.5 meter) from equipment.</i>				
<i>Sound power measured per ISO-9614-2.</i>				
Weight				
Models with wetted section materials coded:				
	A	44.9 kg	99 lb	
	I	74.8 kg	165 lb	
	S	73.5 kg	162 lb	
	C, P	45.4 kg	100 lb	
	K	53.0 kg	117 lb	
Notes				
*May vary based on pump materials, suction condition, discharge head, pressure, and fluid type.				
All trademarks or registered trademarks are the property of their respective owners.				

California Proposition 65

CALIFORNIA RESIDENTS

 **WARNING:** Cancer and reproductive harm – www.P65warnings.ca.gov.

Customer Services/Guarantee

CUSTOMER SERVICES

If you require spare parts, please contact your local distributor, providing the following details:

- Pump Model
- Type
- Serial Number, and
- Date of First Order

GUARANTEE

All VERDER pumps are warranted to the original user against defects in workmanship or materials under normal use (rental use excluded) for two years after purchase date. This warranty does not cover failure of parts or components due to normal wear, damage or failure which in the judgment of VERDER arises from misuse.

Parts determined by VERDER to be defective in material or workmanship will be repaired or replaced.

LIMITATION OF LIABILITY

To the extent allowable under applicable law, VERDER's liability for consequential damages is expressly disclaimed. VERDER's liability in all events is limited and shall not exceed the purchase price.

WARRANTY DISCLAIMER

VERDER has made an effort to illustrate and describe the products in the enclosed brochure accurately; however, such illustrations and descriptions are for the sole purpose of identification and do not express or imply a warranty that the products are merchantable, or fit for a particular purpose, or that the products will necessarily conform to the illustration or descriptions.

PRODUCT SUITABILITY

Many regions, states and localities have codes and regulations governing the sale, construction, installation and/or use of products for certain purposes, which may vary from those in neighboring areas. While VERDER attempts to assure that its products comply with such codes, it cannot guarantee compliance, and cannot be responsible for how the product is installed or used. Before purchasing and using a product, please review the product application as well as the national and local codes and regulations, and be sure that product, installation, and use complies with them.

Original instructions. This manual contains English.
Revision B, March 2023

Austria

Verder Austria
Eitnergasse 21/Top 8
A-1230 Wien
AUSTRIA
Tel: +43 1 86 51 074 0
Fax: +43 1 86 51 076
e-mail: office@verder.at

Belgium

Verder nv
Kontichsesteenweg 17
B-2630 Aartselaar
BELGIUM
Tel: +32 3 877 11 12
Fax: +32 3 877 05 75
e-mail: info@verder.be

China

Verder Shanghai Instruments and Equipment Co., Ltd
Building 8 Fuhai Business Park No. 299
Bisheng Road, Zhangjiang Hiteck Park
Shanghai 201204
CHINA
Tel: +86 21 33932950
Fax: +86 21 33932955
e-mail: info@verder.cn

Bulgaria

Verder Bulgaria Ltd
Vitosh department,
Manastriski Livadi Zapad
district,
110 Bulgaria Blvd., 2-nd
Floor, apt. 15-16,
1618 - Sofia
BULGARIA
Tel: 0878407370
Fax: 02 9584085
email: office@verder.bg

Czech Republic

Verder s.r.o.
Vodnanská 651/6 (vchod
Chlumecka 15)
198 00 Praha 9-Kyje
CZECH REPUBLIC
Tel: +420 261 225 386-7
Web: <http://www.verder.cz>
e-mail: info@verder.cz

France

Verder France
8 Allée Rosa Luxembourg
Immeulde Arizona
95610 Eragny sur Oise
FRANCE
Tel: +33 173 43 98 41
Fax: +33 134 64 44 50
e-mail: info@verder.fr

Germany

Verder Deutschland GmbH
Retsch-Allee 1-5
42781 Haan
GERMANY
Tel: 02104/2333-200
Fax: 02104/2333-299
e-mail: info@verder.de

Hungary

Verder Hungary Kft
Budafoke ut 187 - 189
HU-1117 Budapest
HUNGARY
Tel: 0036 1 3651140
Fax: 0036 1 3725232
e-mail: info@verder.hu

India

Verder India Pumps Pvt
Ltd.
Plot No-3B, D-1 Block,
MIDC Chinchwad,
Pune - 411019
INDIA
e-mail: sales@verder.co.in
www.verder.co.in

Italy

Verder Italia
Via Maestri Del lavoro, 5
02100 Vazia, Rieti
ITALY
Tel: +39 07 46 229064
e-mail: info@verder.it

Korea

Verder Korea
15-26, Beodeul-ro 1362
Paltan-myun, Hwaseong-si
Gyeonggi-do, 18578
KOREA
Tel: +82 31 355 0316
e-mail: sales@verder.kr

The Netherlands

Verder BV
Leningradweg 5
NL 9723 TP Groningen
THE NETHERLANDS
Tel: +31 50 549 59 00
Fax: +31 50 549 59 01
e-mail: info@verder.nl

Poland

Verder Polska
ul.Porcelanowa 23
PL-40 036 Katowice
POLAND
Tel: +48 32 78 15 032
Fax: +48 32 78 15 034
e-mail: verder@verder.pl

Romania

Verder România
Drumul Balta Doamnei
no 57-61
Sector 3
CP 72-117
032624 Bucuresti
ROMANIA
Tel: +40 21 335 45 92
Fax: +40 21 337 33 92
e-mail: office@verder.ro

Slovak Republik

Verder Slovakia s.r.o.
Silacska 1
SK-831 02 Bratislava
SLOVAK REPUBLIK
Tel: +421 2 4463 07 88
Fax: +421 2 4445 65 78
e-mail: info@verder.sk

South Africa

Verder SA
197 Flaming Rock Avenue
Northlands Business Park
Newmarket Street
ZA Northriding
SOUTH AFRICA
Tel: +27 11 704 7500
Fax: +27 11 704 7515
e-mail: info@verder.co.za

Switzerland

Verder Deutschland GmbH
Sales Switzerland
Retsch-Allee 1-5
D-42781 Haan
GERMANY
Tel: +41 (0)61 331 33 13
Fax: +41 (0)61 331 63 22
e-mail: info@verder.ch

United Kingdom

Verder UK Ltd.
Unit 3 California Drive
Castleford, WF10 5QH
UNITED KINGDOM
Tel: +44 (0) 1924 221 001
Fax: +44 (0) 1132 465 649
e-mail: info@verder.co.uk

United States of America

Verder Inc.
312 Corporate Parkway
Suite 101
Macon, GA 31210
USA
Tel: +1 877 783 7337
Fax: +1 478 476 9867
e-mail:
sales@verderus.com