

## **VERDERAIR CONT-EX**

Solid machined air operated diaphragm pumps

## TABLE OF CONTENTS

Pump Matrix	3
Atex	4
Warnings	5
Installation	7
Operation	10
Maintenance / repair	11
Trouble shooting	17
Parts and kits	18
Torque Values	18
Exploded views	19
Dimensions	22
Performance charts	23
Technical data	25
Customer services & guarantee	26

## PUMP MATRIX

Before putting your pump in operation, check the identification plate (ID) on the pump. The ID is mentioning the year of construction, the serial number and the construction code of the pump. Use the matrix below to define the components of your pump. Make sure the wetted parts of the pump are compatible to the pumped liquid.

**NOTE:**

- In case of doubt, please contact your local supplier. ([www.verderair.com](http://www.verderair.com))
- To build a pump code, please use the below coding system or use the pump configurator on [www.verderair.com](http://www.verderair.com).

### PUMP CODING VA-C

Pump size	Housing and center section	valve material	Diaphragm material
10 : 3/8"	GG : Conductive Polyethylene	TF : PTFE ball valve	TO : PTFE overmolded
20 : 1/2"		EP : EPDM ball valve	EO : EPDM overmolded
50 : 3/4"		CV : PE cylinder valve	
130 : 1 1/4"		SV: PTFE spring loaded valve	
		SS : SS316 ball valve	

EXAMPLE : VA-C20GG TF TO

*ID-Plate of Pump*

## ATEX

All pumps of the CONT-EX range are manufactured from Conductive Polyethylene and are ATEX certified  II 2G/2GD Ex h IIC/IIIC T70° Gb/Gb Db. The pumps have to be grounded following the instructions on page 8.

When using conductive diaphragms at the liquid side, no restrictions are applicable.







When using non - conductive diaphragms, the following protective measures have to be taken into account:

- Pumped liquid must be conductive or soluble in water
- Dry running have to be prevented by means of monitoring systems which are placed in the pump system

The following warnings are for the setup, use, grounding, maintenance, and repair of this equipment. The exclamation point symbol alerts you to a general warning and the hazard symbol refers to procedure specific risk. When these symbols appear in the body of this manual, refer back to these warnings. Additional, product-specific warnings may be found throughout the body of this manual where applicable.

## WARNINGS

**WARNING**

**FIRE AND EXPLOSION HAZARD**

Flammable fumes, such as solvent and paint fumes, in work area can ignite or explode. To help prevent fire and explosion:

- Use equipment only in well ventilated area.
- Eliminate all ignition sources; such as pilot lights, cigarettes, portable electric lamps, and plastic drop cloths (potential static arc).
- Keep work area free of debris, including solvent, rags and gasoline.
- Do not plug or unplug power cords, or turn power or light switches on or off when flammable fumes are present.
- Ground all equipment in the work area. See grounding instructions.
- Use only grounded hoses.
- If there is static sparking or you feel a shock, stop operation immediately. Do not use equipment until you identify and correct the problem.
- Keep a working fire extinguisher in the work area.

Static charge may build up on plastic parts during cleaning and could discharge and ignite flammable materials and gases. To help prevent fire and explosion:

- Clean plastic parts in a well ventilated area.
- Do not clean with a dry cloth.

**WARNING****EQUIPMENT MISUSE HAZARD**

Misuse can cause death or serious injury.

- Do not operate the unit when fatigued or under the influence of drugs or alcohol.
- Do not exceed the maximum working pressure or temperature rating of the lowest rated system component. See Technical Data in all equipment manuals.
- Use fluids and solvents that are compatible with equipment wetted parts. See Technical Data in all equipment manuals. Read fluid and solvent manufacturer's warnings. For complete information about your material, request MSDS from distributor or retailer.
- Do not leave the work area while equipment is energized or under pressure. Turn off all equipment and follow the Pressure Relief Procedure in this manual when equipment is not in use.
- Check equipment daily. Repair or replace worn or damaged parts immediately with genuine manufacturer's replacement parts only.
- Do not alter or modify equipment.
- Use equipment only for its intended purpose. Call your distributor for information.
- Route hoses and cables away from traffic areas, sharp edges, moving parts, and hot surfaces.
- Do not kink or over bend hoses or use hoses to pull equipment.
- Keep children and animals away from work area.
- Comply with all applicable safety regulations.

**PRESSURIZED EQUIPMENT HAZARD**

Fluid from dispense valve, leaks, or ruptured components can splash in the eyes or on skin and cause serious injury.

- Follow Pressure Relief Procedure in this manual, when you stop the pump and before cleaning, checking, or servicing equipment.
- Tighten all fluid connections before operating the equipment.
- Check hoses, tubes, and couplings daily. Replace worn or damaged parts immediately.

**THERMAL EXPANSION HAZARD**

Fluids subjected to heat in confined spaces, including hoses, can create a rapid rise in pressure due to the thermal expansion. Over-pressurization can result in equipment rupture and serious injury.



- Open a valve to relieve the fluid expansion during heating.
- Replace hoses proactively at regular intervals based on your operating conditions.

**WARNING****PLASTIC PARTS CLEANING SOLVENT HAZARD**

Use only compatible water-based solvents to clean plastic structural or pressure-containing parts. Many solvents can degrade plastic parts and cause them to fail, which could cause serious injury or property damage. See Technical Data in this and all other equipment instruction manuals. Read fluid and solvent manufacturer's warnings.

**TOXIC FLUID OR FUMES HAZARD**

Toxic fluids or fumes can cause serious injury or death if splashed in the eyes or on skin, inhaled, or swallowed.

- Read MSDS's to know the specific hazards of the fluids you are using.
- Route exhaust away from work area. If diaphragm ruptures, fluid may be exhausted with air.
- Store hazardous fluid in approved containers, and dispose of it according to applicable guidelines.
- Always wear impervious gloves when cleaning equipment.

**BURN HAZARD**

Equipment surfaces and fluid that's heated can become very hot during operation. To avoid severe burns:

- Do not touch hot fluid or equipment.
- Wait until equipment/fluid has cooled completely.

**PERSONAL PROTECTIVE EQUIPMENT**

You must wear appropriate protective equipment when operating, servicing, or when in the operating area of the equipment to help protect you from serious injury, including eye injury, inhalation of toxic fumes, burns, and hearing loss.



This equipment includes but is not limited to:

- Protective eyewear, gloves, and hearing protection
- Protective clothing

## INSTALLATION

PLEASE CHECK THE ADDITIONAL DELIVERED EXPLODED VIEW FOR ALL POSITION NUMBERS

### Tighten Fasteners Before Setup

Before using the pump for the first time, check and retorque the housing bolts (23). Also the valve stops of the discharge valves (09) have to be checked. Also after the first day of operation, after periods of important temperature fluctuations, after

transport, after dismantling of the pump and after periods when the pump hasn't been working the stops, plugs and housing bolts have to be checked. For the housing bolts please use the torque values as mentioned on page 18.

### Recommended installation drawing

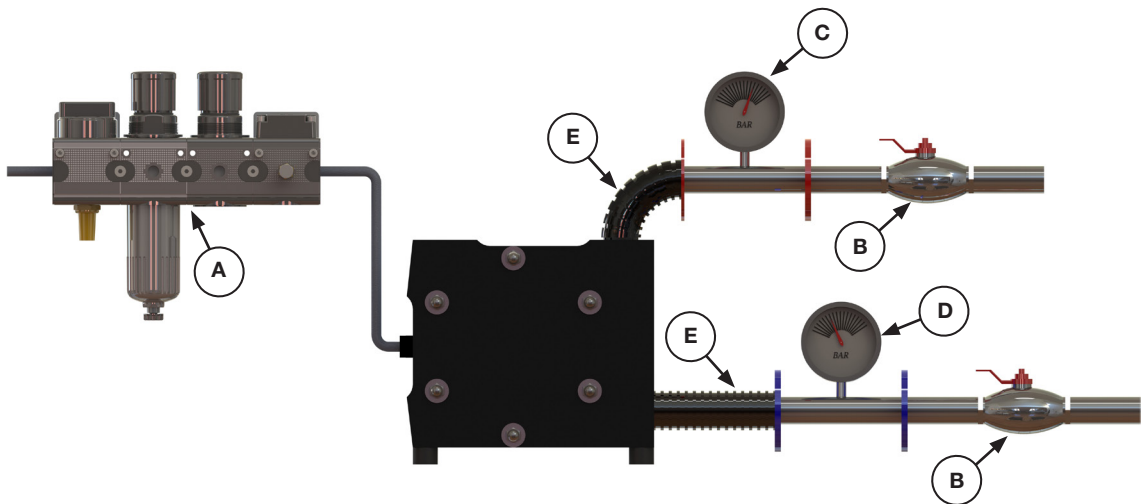
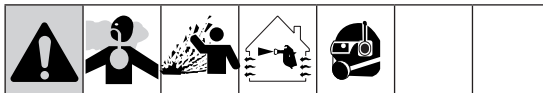

Figure 1 showing the installation of the pump

- A** Air Control pro unit consists of:
- On/of valve
  - Pressure regulator
  - Throttle valve
  - Soft start valve
- B** Isolating valve
- C** Discharge gauge
- D** Suction gauge
- E** Flexible connection

**Mounting**



- The pump exhaust air may contain contaminants. Ventilate to a remote area. See Air Exhaust Ventilation on page 9.
- Never move or lift a pump under pressure. If dropped, the fluid section may rupture. Always follow the Pressure Relief Procedure on page 10 before moving or lifting the pump.

1. Be sure the mounting surface can support the weight of the pump, hoses and accessories, as well as the stress caused during operation.
2. For ease of operation and service, mount the pump so air inlet, fluid inlet and fluid outlet ports are easy accessible.

**Grounding**

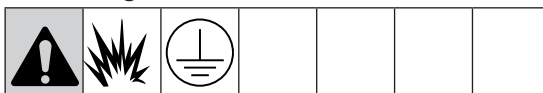

The equipment must be grounded. Grounding reduces the risk of static and electric shock by providing an escape wire for the electrical current due to static build up or in event of a short circuit. In the site housing a grounding connection is included.

Check your system electrical continuity after the initial installation. Set up a regular schedule for checking continuity to be sure proper grounding is maintained.

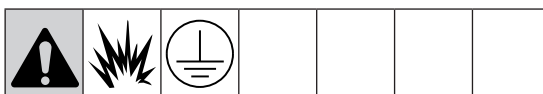

Follow your local fire codes. When pumping flammable fluids, **always** ground the entire fluid system as described.

**Air Line**

See recommended installation drawing on page 7.

1. Install an air regulator and gauge. Set pressure of the driving air should be limited to the pressure required to run the pump on the desired working point. Setting the pressure too high will cause higher wear of the pump and will increase the compressed air consumption. The fluid stall pressure will be the same as the setting of the air regulator.
2. If the air regulator do not have a bleed off function to relieve trapped air, or the air regulator is not placed close to the pump, locate a bleed-type master air-valve close to the pump. Be sure the valve is easily accessible from the pump.



Trapped air can cause the pump to cycle unexpectedly, which could result in serious injury from splashing.

3. The master air valve will be used to regulate the flow rate of the air to the pump. By using a throttle valve, it is possible to regulate the pump speed even at the lower end of the curves.
4. Install a grounded, flexible air hose between the accessories and the pump air inlet. The inner diameter of the hose have to be the same diameter of the air connection of the pump or bigger.



## Air Exhaust Ventilation



Do not restrict the air exhaust port. Excessive exhaust restriction can cause erratic pump operation. At a diaphragm rupture, it is possible the pumped liquid will escape through the muffler. To prevent this the air exhaust need to be remote to a safe environment.

## Fluid suction line

1. A shut of valve should be installed just before the pump to isolate the pump from the system for maintenance and installation.
2. Always use a flexible connection to avoid vibrations being brought into the piping system.
3. Use a suction line which can stand vacuum. By the pumping action, vacuum will be created at the suction side of the pump.
4. The inner diameter of the hose should be equal to the connection diameter of the pump.
5. If the inlet pressure to the pump is more than 25% of the outlet working pressure, the ball check valves will not close fast enough, resulting in inefficient pump operation and is a possible cause of noise.
6. Inlet pressure greater than 1 bar (15 PSI), diaphragm life will be shortened.

## Fluid outlet line

1. A shut of valve should be installed just after the pump to isolate the pump from the system for maintenance and installation. A drain valve should be installed to relief the pressure of the pump before starting maintenance work at the pump.
2. Always use a flexible connection to avoid vibrations being brought into the piping system.

## Fluid inlet and outlet ports

VA-C series of pump are having the suction and discharge connections integrated in the center block. Suction connection is horizontal and discharge vertical. Pay attention to this configuration as this is only valid for correct pump function.

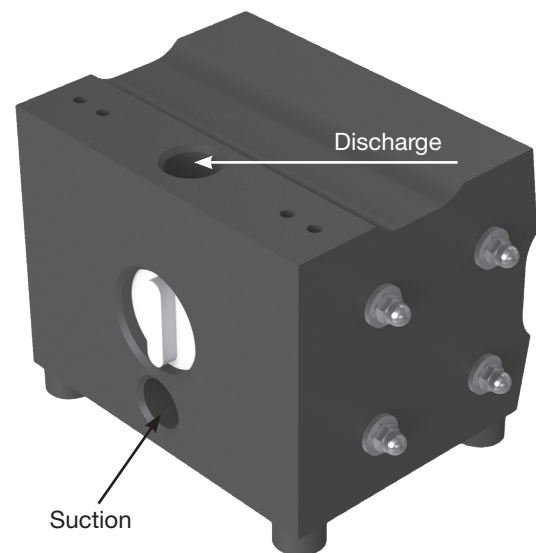

Figure 2

## Installation remarks



1. VA-C pumps must be installed load free to avoid possible damage of pumps and/or installation.
2. VA-C pumps will be delivered with blind plugs to prevent dust or other materials to enter the pump. Those plugs have to be removed before installing the pump!
3. As UV – radiation can damage Polyethylene. This must taken in account by installing VA-C pumps are made out of Conductive PE.
4. The air-valves used in VA-C pumps are manufactured with tight tolerances. They should be used with clean, dry and oil-free compressed air. If the quality of the compressed air at the place where the pump is installed is not optimal, it is possible to install a dryer and/or a water separator. Please contact your distributor for more detailed information.

5. VA-C pumps are dry self-priming. So they don't need to be filled before first use. The figures of the possible suction heights can be found in the technical information. (see page 25).
6. VA-C pumps will building up pressure at the liquid side up to the pressure set on the compressed air-inlet of the pump. If this pressure is higher than the rated pressure of the discharge line, a pressure relief valve or another pressure safety equipment should be installed at the discharge side of the pump.
7. VA-C pumps can stall against a closed discharge line without damage. The pump will stop working when the pressure at the liquid side of the diaphragms is equal (or higher) then the compressed air pressure at the air-side of the diaphragm. As soon the pressure at the liquid side will drop below the compressed air pressure, the pump will restart automatically.

Due to internal losses, occasionally the pump can make a stroke during stalling.

## OPERATION

### Pressure relief procedure

						
Trapped air can cause the pump to cycle unexpectedly, which could result in serious injury from splashing.						

1. Shut off the air supply to the pump.
2. Open the dispensing valve, if used.
3. Open the fluid drain valve to relieve fluid pressure. Have a container ready to catch the drainage.

### Flush pump before first use

The pump was tested before leaving the factory. Residue of the testing water can be left in the pump. To avoid contamination, flush the pump before first use.



### Starting and adjusting the pump

1. Be sure the pump is properly grounded. See page 8 for proper **grounding**.
2. Check fittings to be sure they are tight. Tighten fluid inlet and outlet fittings securely.
3. Place the suction tube (if used) in fluid to be pumped.

**NOTE:** If fluid inlet pressure to the pump is more than 25% of outlet working pressure, the ball check valves will not close fast enough, resulting in inefficient pump operation.

4. Place the end of the fluid hose into an appropriate container.
5. Close the fluid drain valve.
6. Back out the air regulator knob, and open all bleed-type master air valves.
8. Slowly increase air pressure with the air regulator until the pump starts to cycle. Allow the pump to cycle slowly until all air is pushed out of the lines and the pump is primed. Trapped air can cause the pump to cycle unexpectedly, which could result in serious injury from splashing.
9. If you are flushing, run the pump long enough to thoroughly clean the pump and hoses.
10. Close the bleed-type master air valve.

### Pump shutdown

						
---	--	--	--	--	--	--

At the end of the work shift and before you check, adjust, clean or repair the system, follow **Pressure Relief Procedure**, in the left column here.

## Special precautions

1. When medium is left in the pump chambers, this can generate chemical reactions when pumping another fluid. Always flush pumps with a neutral fluid before changing from medium.
2. Take care liquids left in the pump chamber can't freeze, this can damage the pump.
3. It is possible to run the pumps on nitrogen gas instead of compressed air. Take care about sufficient ventilation around the pump as the exhaust of the pump will put nitrogen gas in the atmosphere.
4. Using the pump submerged: It is necessary to connect the air outlet of the pump to the atmosphere be using a flexible hose, to prevent liquid to enter the air side of the pump. Take in consideration , all external parts of the pump must be 100% resistance to the medium where the pump is placed in. Special care have to been taken the pump is standing 100% vertical and can't start to float in all circumstances.
5. In case of big changes in temperature while operating, it is necessary to control the tension on the bolts carefully. Sudden big temperature shocks can cause over or under tightening of the pump and will lead to leaks and/or damage the pump.

## MAINTENANCE / REPAIR

### Flushing and storage

Flush the pump often enough to prevent the fluid you are pumping from drying or freezing in the pump and damaging it. Always flush the pump and follow the Pressure relief Procedure on page 10 before storing it for any length of time. Use a compatible flushing agent.

### Tightening Threaded connections

Before each use, check all hoses for wear or damage and replace as necessary. Check to be sure all threaded connections are tight and leak-free. Tighten and retorque the pump if necessary. Use torque values on page 18.

### Preventive maintenance schedule

Establish a preventive maintenance schedule, based on the pump's service history. This is especially important for prevention of spills or leakage due to diaphragm failure.

## Disassembly

### IMPORTANT:

- **Follow the Pressure Relief Procedure at page 10 before starting to work at the pump !**
- **After a diaphragm rupture always make sure no liquid is left at the air side of the pump. Especially the muffler (07) have to be checked before opening the pump.**

The fluid side of the range of VA-C pumps are built together the same way. The only difference are the number of assembly (23) pins used. VA-C pumps are having different right and left side housings (02 and 03).

1. The center section has the same built up for VA-C50 and VA-C130. The air valves for the VA-C10 and the VA-C20 are not having an air valve shaft. On those pumps the diaphragm shaft (19) is also used as piston shaft. Due to this the VA-C10 and VA-C20 are not having diaphragm shaft o-rings and diaphragm shaft bearings (20) mounted in the center housing.

Every Verderair CONT-EX pump is delivered with a tool to disassemble the air valve.



Figure 3.1: air-valve tool

Special tools to easy disassemble the valve plugs (9) can be ordered separately. See figure 3.2.



Figure 3.2: plug tools

## Disassembly of the housing

Unscrew the bolts on the assembly pins (23) on one side using a socket wrench (see figure 4). Remove the washers, then remove the side housing (02-03). Take care not to damage the sealing surfaces in contact with the diaphragms. Remove the assembly pins from the other side housing and remove the second side housing.

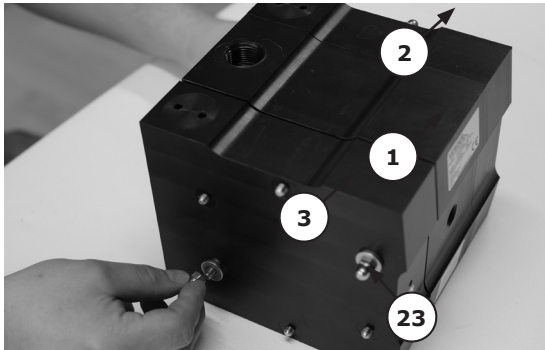

Figure 4



Remove the muffer and the housing o-rings (22) (see figure 5).

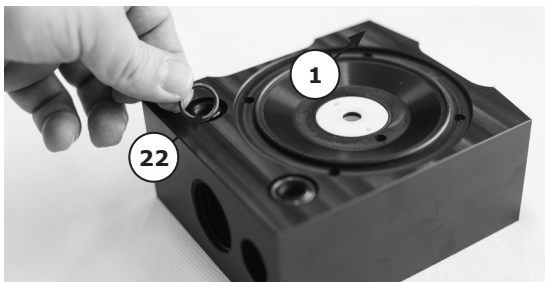

Figure 5

## Disassembly of the valve seats and valve balls (or cylindrical valves)

To have access to valve seat you need to disassembly the pump side housing first. Unscrew the liquid plug (09) at the top of the side housing (02-03) with the special tool (see figure 6 and 7).



Figure 6



Figure 7

Remove the liquid plug and remove the valve.

Put a screwdriver in the liquid flow hole of side section and gentle push-up seat to remove it. Take out second valve. See figure 8

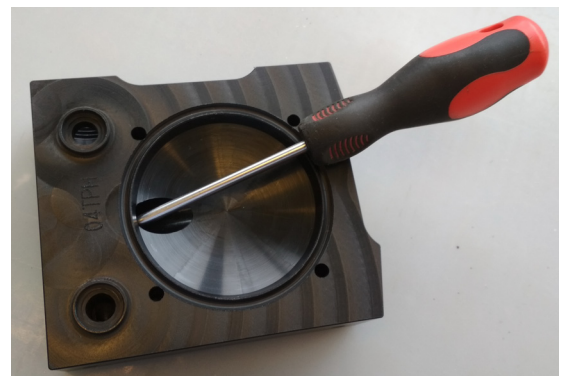

Figure 8

Disassembly of the diaphragms and diaphragm shaft.

Unscrew one diaphragm (17) (left turning) of the diaphragm shaft (19\*).

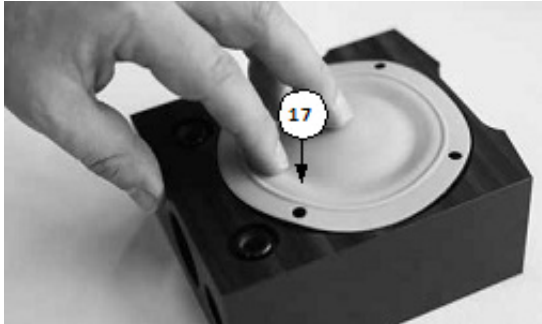

Figure 9

Pull the diaphragm shaft (19\*) with the second diaphragm out of the centre housing (01). Unscrew the second diaphragm from the shaft.

\* For VA-C10 and VA-C20, part of the air-valve (27).

Disassembly of the centre housing.

For VA-C50 and VA-C130 (not for VA-C10 and VA-C20). Remove carefully the diaphragm shaft bearings and o-rings (20) from their grooves in the centre housing. (If disassembled they need to be replaced!) Take care not to damage the edges of the grooves (see Figure 10).



Figure 10

Unscrew the muffler (07)

Unscrew both end caps of the air valve (27) by using the special tool (see Figure 11).

Push out the main-valve and the air valve shaft (air valve shaft not for VA-C10 and VA-C20). Push out the air-valve housing.

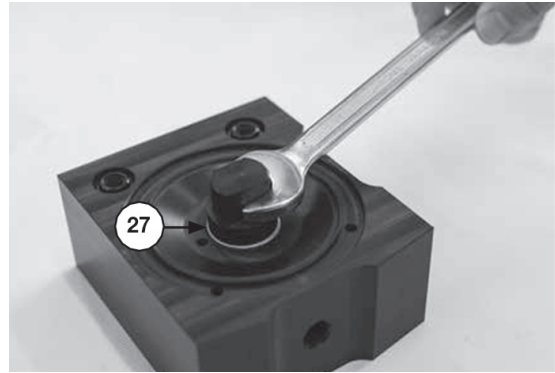

Figure 11

**Assembly**

Before starting to assemble please check all parts on possible damages. Especially the sealing area of the diaphragms have to be free from scratches (see Figure 12).

Assembly of the centre housing.

Remove the end caps, the main-valve and the air valve shaft out of the the air-valve (27). Screw one end cap flush into the centre housing (01) by using the special tool (see Figure 11). Put 1 off the six air- valves housing o-rings part of (27) into the end cap.

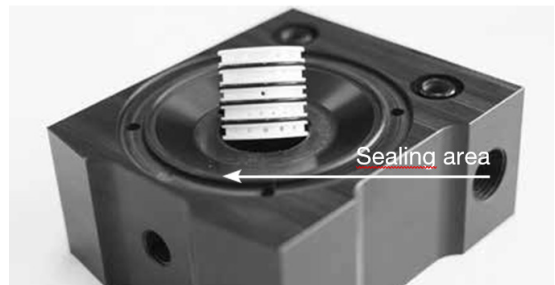

Figure 12

Push the air-valve housing in the centre housing until it touches the end cap. Be sure the 4 air valve- housing o-rings are kept in their seat. Push the main-valve and the air valve shaft (air valve shaft not for VA-C10 and VA-C20) in the centre housing.

Put the last air-valve housing o-ring on top of it and screw the second end cap flush with the centre housing using the special tool (see Figure 11).

Screw the centre housing plug (04) in the bottom connection (for standard pumps) of the centre housing (01). Screw the muffler (07) into the centre housing.>>



For VA-C50 and VA-C130 only :  
put the diaphragm shaft o-rings (20) in the groove of the centre housing, by forming them as kidney's with locking ring pliers (see Figure 13).

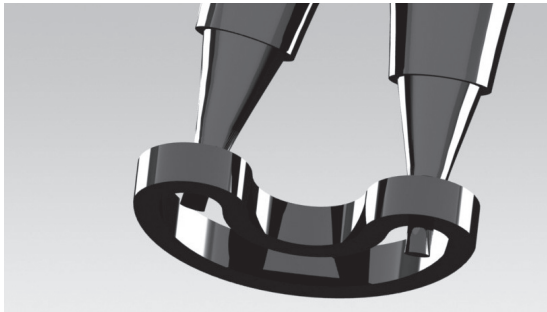

Figure 13

Push them into the groove with a round tool. On the same way the diaphragm shaft bearings can be placed in the groove.

#### Assembly of the diaphragms and diaphragm shaft.

Screw the diaphragm shaft screws (18) into the diaphragms and tighten. Screw one diaphragm (17) completely into the diaphragm shaft (19) (see Figure 14).

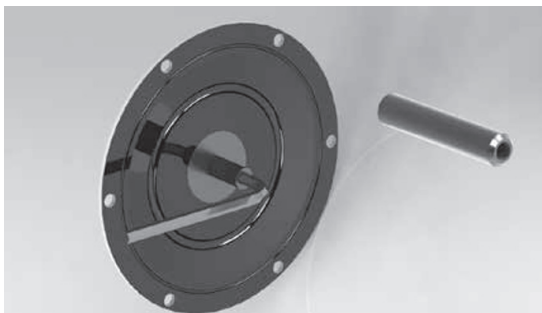

Figure 14

Push the shaft in the centre housing (1) and screw the second diaphragm (17) completely into the shaft(19) (see Figure 15).



Figure 15

Adjust, when necessary, the position of the holes for the assembly pins by turning one of the diaphragms a little backwards.

#### Assembly of the housing.

Place O-rings (22) into side sections (2 and 3). Place the valve ball (11) or the cylindrical valve (10) in to the side section integrated suction seat (see Figure 16.1), place valve seat (12) in to side section and pay attention that valve seat flow bore will be in the center with internal channel of side section (see Figure 16.2). Put second valve ball or cylindrical valve inside the seat. Place an o-ring (14) on the top edge of valve seat (see Figure 16.3) and close valve with valve plug (09) using special tool. Screw in plug flush to side housing top surface (Figure 16.4). Preassemble closed nuts and one flat washer at the one end of each assembly pin. Push the assembly pins (23) through one of the side housings (Figure 16.5).

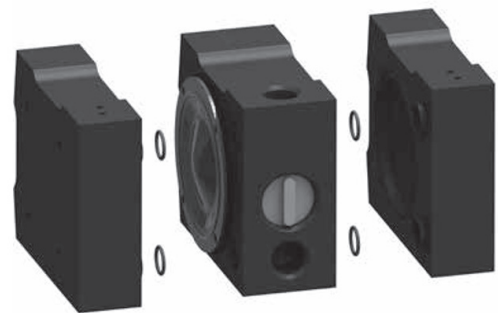

Figure 16



Figure 16.1

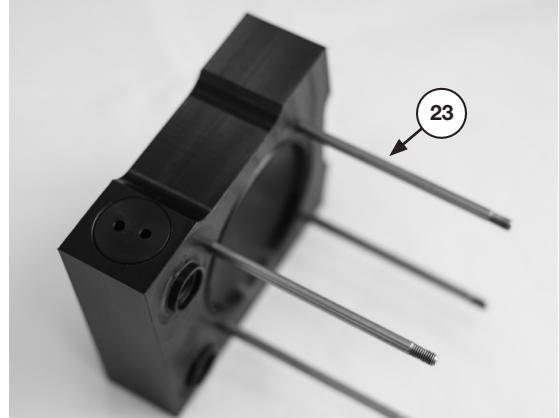

Figure 16.5

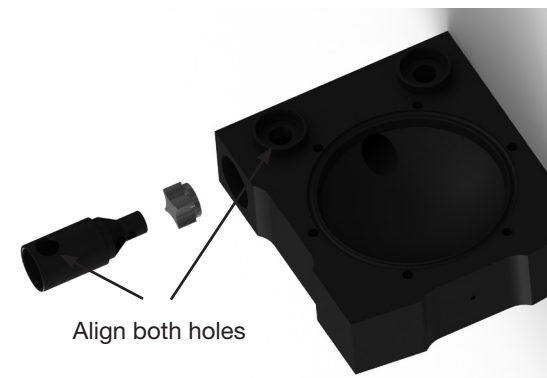

Figure 16.2

Put the washers on the assembly pins and put the bolts on. Fasten the bolts crosswise up to the torque values as mentioned on page 18.

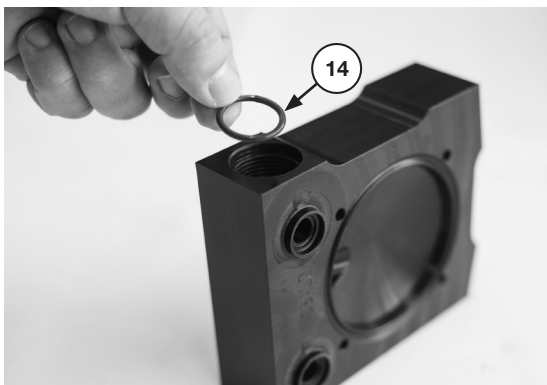

Figure 16.3



Figure 17

Always test the pump on leakages before using it.



Figure 16.4

### Spring valve assembly, housing assembly

Connect the spring loaded valve (10) to the valve seat (12) (see figure 18 and 19)



Figure 18

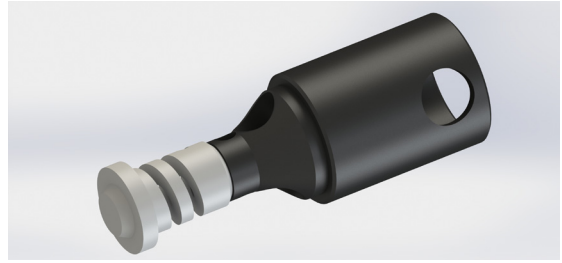

Figure 19

Then connect the spring loaded valve (10) to the valve plug (9) (see figure 20 and 21)

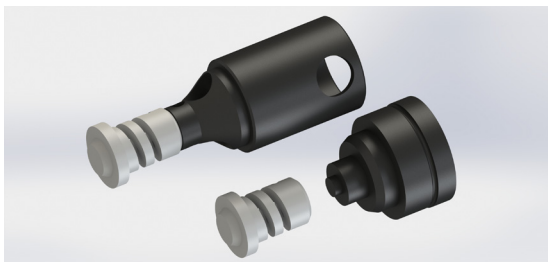

Figure 20

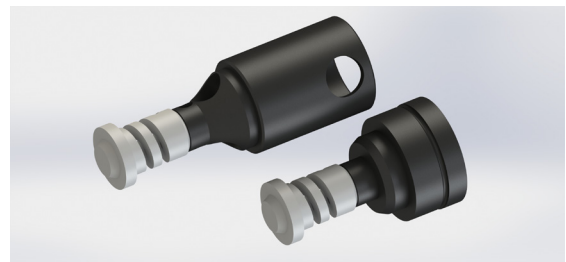

Figure 21

Place valve seat (12) with spring loaded valve (10) it to side section (2 and 3) and pay attention that valve seat flow bore will be in the center with internal channel of side section (see figure 22 and 23)

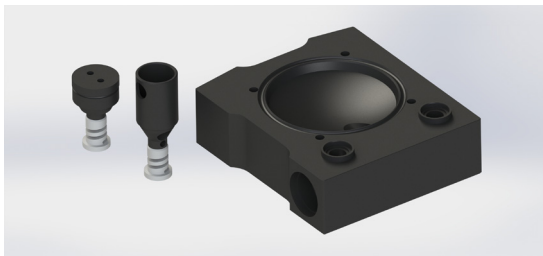

Figure 22

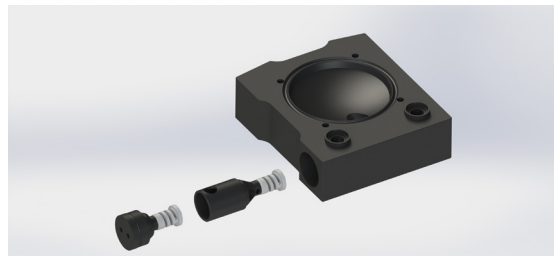

Figure 23

Place an o-ring (14) on the top edge of the valve seat (12) then screw in valve plug (9) with the spring loaded valve (10). Screw in plug flush to side housing top surface (see figure 24 and 25).

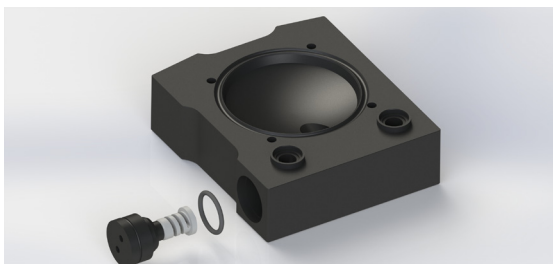

Figure 24

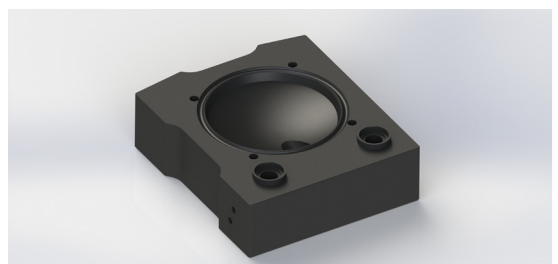

Figure 25

Preassemble closed nuts and one flat washer at the one end of each assembly pin (see figure 22). Then assembly of the complete housing.



Problem	Cause	Solution
Pumps cycles at stall or fails to hold pressure at stall.	- Worn check valves and/or o-rings	- Replace worn parts.
Pump will not cycle, or cycle once and stops.	- Air valve is dirty. - Air valve is leaking - Air valve is blocked - Check if valve ball is not stuck in seat or chamber. - Icing of the muffler and/or air valve. - Not sufficient air pressure  - Discharge line is closed  - Suction line closed  - Diaphragm rupture	- Clean or replace the air valve. Use filtered air! - Replace air valve - Replace air valve - Replace valve balls and/or seats.  - Improve air quality.  - Check air supply system on blockage and/or leakage. Or increase air supply. - Open valve in the discharge line and/or check on blockage. - Open valve in the suction line and/or check on blockage. - Replace the diaphragms and clean the pump.
Pumps operates erratically	- Clogged suction line - Check valves sticky or blocked. - Diaphragm rupture  - Restricted exhaust  - Air valve is leaking or blocked	- Check suction line - Clean or replace check valves.  - Replace the diaphragms and clean the pump. - Remove restriction (check on icing!) and when necessary replace muffler. - Replace air valve
Air bubbles in fluid	- Suction line is loose - Diaphragm rupture  - Suction container empty - Cavitation	- Tighten - Replace the diaphragms and clean the pump. - Fill or replace suction container - Check suction condition and adapt when necessary
Fluid in exhaust air	- Diaphragm rupture	- Replace the diaphragms and clean the pump.
Insufficient discharge pressure	- Not enough air pressure  - Air supply is leaking - Check valves worn - Air valve is leaking	- Increase compressed air pressure or check if no other components are consuming too much air on the same compressed air line. - Check and repair - Replace check valves - Replace air valve
Discharge is decreasing	- Other components are consuming too much air on the same air supply line. - Air supply is reduced  - Suction strainer is blocking - Discharge strainer is blocking - Medium becomes more viscous - Muffler blocked	- Increase the volume of air.  - Check air supply system on blockage and/or leakage. - Clean suction strainer - Clean discharge strainer - Check why and if necessary adjust pump settings. - Clean out or replace. Check on icing!
Pump is running but not enough suction capability	- Pump is running too fast  - Cavitation  - Suction strainer is blocking - Suction line closed  - Worn check valves - Leak in suction line and/or suction connections	- Start-up pump slow running. Once the pump is filled with liquid you can run the pump faster. - Check suction condition and adapt when necessary - Clean suction strainer - Open valve in the suction line and/or check on blockage. - Replace worn parts. - Repair and make leak tight

## PART & KITS

### Parts

SEE SEPERATE PARTS LIST

### Kits

In case of break down, we recommend to have a spare part kit for your pump on stock. Spare part kits contains:

Spare part kit standard, content	Quantity
O-ring side housing (22)	4
Ball (11) / cylinder valve (10)	4
Diaphragm (17)	2
O-ring valve plug	2
Shaft seal (20) (only VA-C50 and VA-C130)	2
Muffler (7)	1
Air valve (27)	1

Spare part kit spring loaded valve, content	Quantity
O-ring side housing (22)	4
Spring loaded valve (10)	4
Diaphragm (17)	2
O-ring valve plug	2
Muffler (7)	1
Air valve (27)	1

Please check the seperate spare parts list for the order nr. for the kit you need for your pump.

## TORQUE VALUES

Torque values for housing bolts assembly in Nm				
Device model	VA-C10	VA-C20	VA-C50	VA-C130
all models	3	4	6	8

Torque values for housing bolts assembly in inlb				
Device model	VA-C10	VA-C20	VA-C50	VA-C130
all models	27	35	53	71

**EXPLODED VIEWS**

VA-C10 & VA-C20

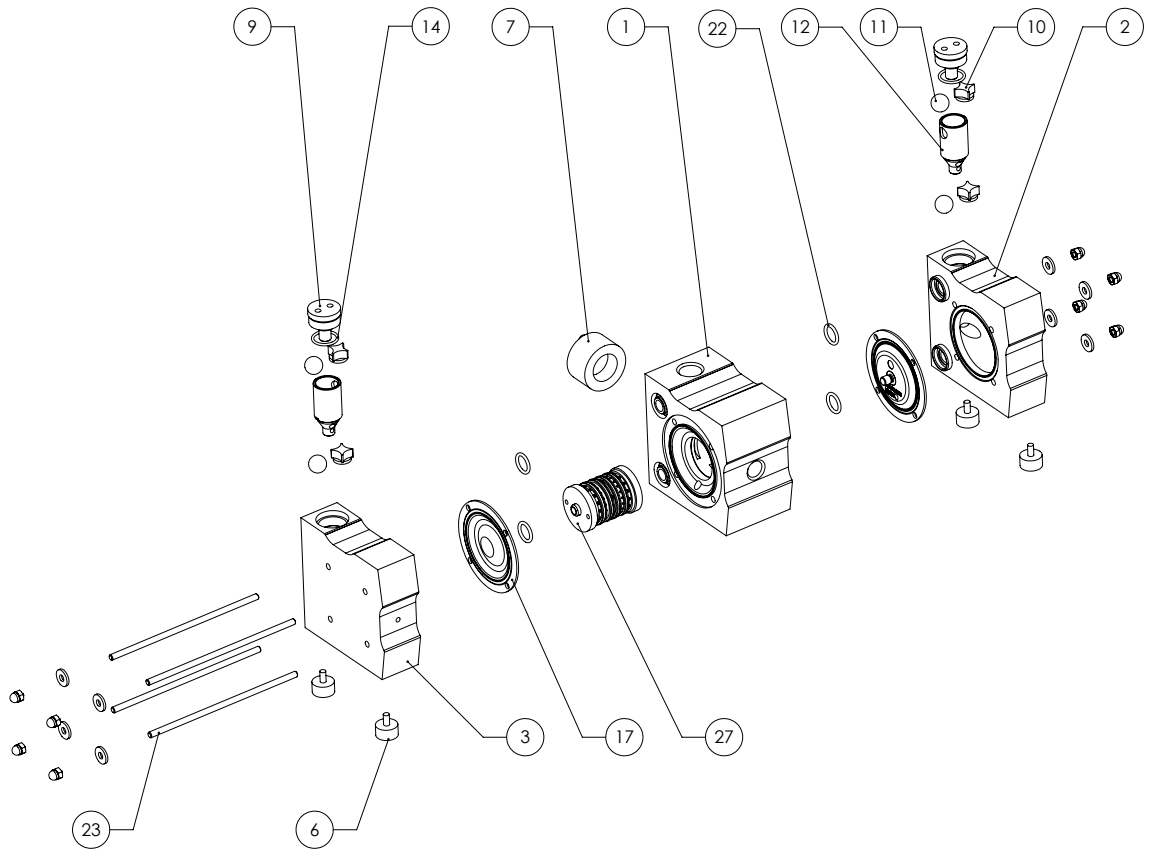

POS. N°	DESCRIPTION	QUANTITY NEEDED
1	CENTER HOUSING	1
2	SIDE HOUSING RIGHT	1
3	SIDE HOUSING LEFT	1
6	SHOCK ABSORBER	4
7	MUFFLER	1
9	VALVE PLUG	2
10	CYLINDER VALVE	4
11	VALVE BALL (*)	4
12	VALVE SEAT(**)	2
14	O-RING SET VALVE PLUG	1
17	DIAPHRAGM	2
22	O-RING SET HOUSING	1
23	ASSEMBLY PIN SET	4
27	AIR VALVE	1

**EXPLODED VIEWS**

VA-C50 & VA-C130

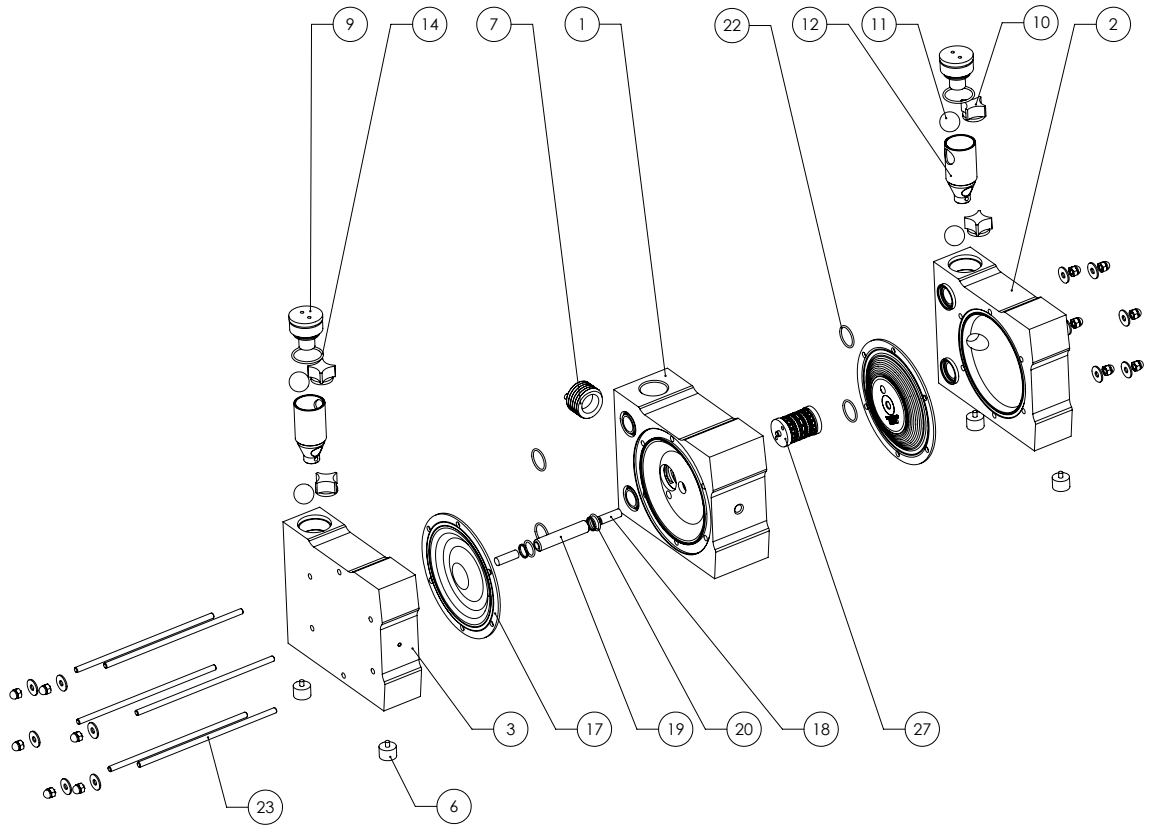

POS. N°	DESCRIPTION	QUANTITY NEEDED
1	CENTER HOUSING	1
2	SIDE HOUSING RIGHT	1
3	SIDE HOUSING LEFT	1
6	SHOCK ABSORBER	4
7	MUFFLER	1
9	VALVE PLUG	2
10	CYLINDER VALVE	4
11	VALVE BALL (*)	4
12	VALVE SEAT(**)	2
14	O-RING SET VALVE PLUG	1
17	DIAPHRAGM	2
18	DIAPHRAGM SHAFT SCREW	2
19	SHAFT	1
20	BEARING SET SHAFT	1
22	O-RING SET HOUSING	1
23	ASSEMBLY PIN SET	6
27	AIR VALVE	1

**EXPLODED VIEWS**

**VA-C10 SV & VA-C20 SV OPTION**

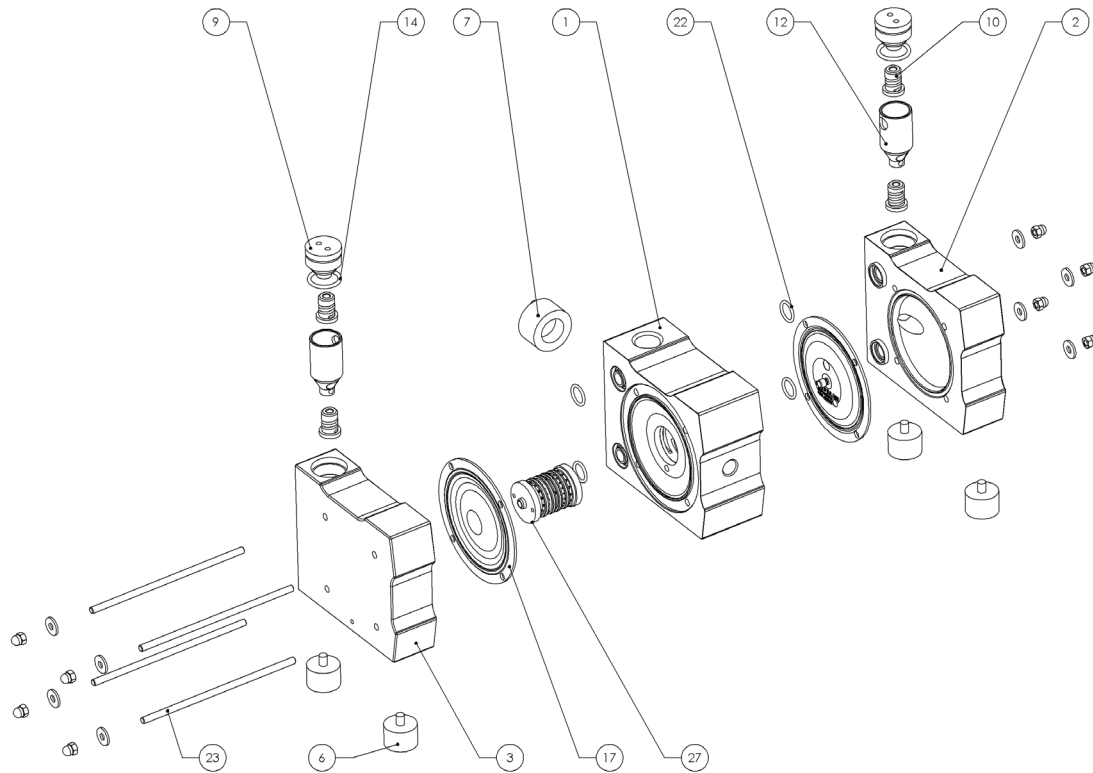

POS. N°	DESCRIPTION	QUANTITY NEEDED
1	CENTER HOUSING PE-C	1
2	SIDE HOUSING RIGHT PE-C	1
3	SIDE HOUSING LEFT PE-C	1
6	SHOCK ABSORBER	4
7	MUFFLER	1
9	VALVE PLUG PE-C SV	2
10	SPRING VALVE PTFE	4
12	VALVE SEAT PE-C SV	2
14	O-RING ENCAP. PLUG SET	1
14	O-RING EPDM PLUG SET	1
17	DIAPHRAGM EPDM	2
17	DIAPHRAGM PTFE	2
22	O-RING HOUSING ENCAP. SET	1
22	O-RING HOUSING EPDM SET	1
23	ASSEMBLY PIN SET	4
27	AIR VALVE	1

**DIMENSIONS**

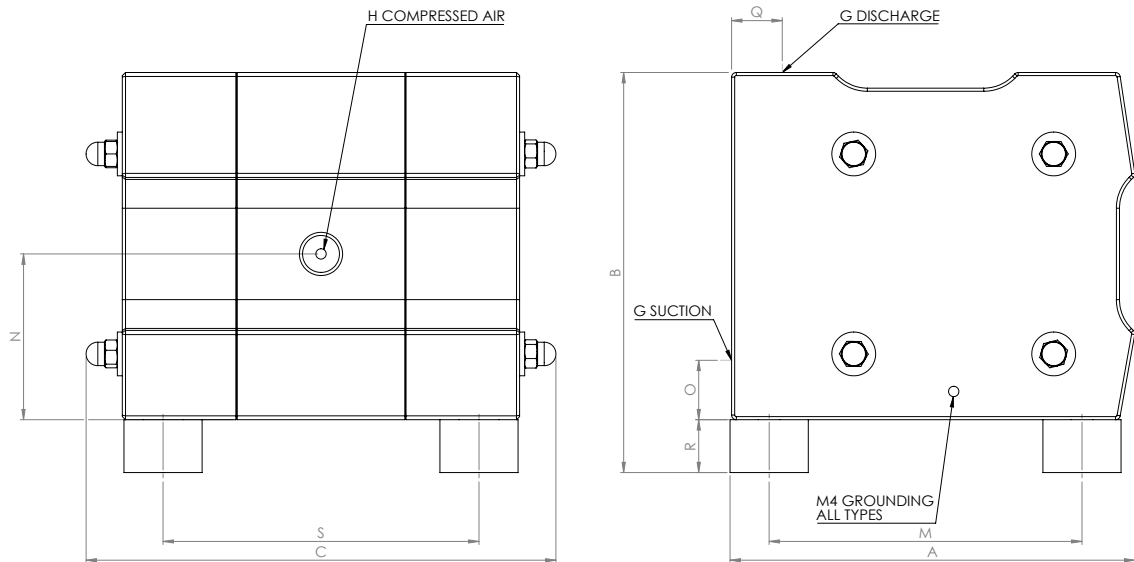

TYPE	A	B	C	G	H	M	N	O	Q	R	S
VA-C10	90	94	132	NPT 3/8"	R 1/4"	71	41	14	15	8	98
VA-C20	130	128	150	NPT 1/2"	R 1/4"	100	53	19	19	17	101
VA-C50	180	172	197	NPT 3/4"	R 1/4"	150	75	27	23	17	145
VA-C130	246	223	259	NPT 1-1/4"	R 1/4"	215	100	37	33	17	200

*in mm*

TYPE	A	B	C	G	H	M	N	O	Q	R	S
VA-C10	3,54	3,70	5,20	NPT(f) 3/8"	R 1/4"	2,80	1,61	0,55	0,59	0,31	3,86
VA-C20	5,12	5,04	5,91	NPT(f) 1/2"	R 1/4"	3,94	2,09	0,75	0,75	0,67	3,98
VA-C50	7,09	6,77	7,76	NPT(f) 3/4"	R 1/4"	5,91	2,95	1,06	0,91	0,67	5,71
VA-C130	9,69	8,78	10,20	NPT(f) 1-1/4"	R 1/4"	8,46	3,94	1,46	1,30	0,67	7,87

*in inches*

**PERFORMANCE CHARTS**

**VA-C10**

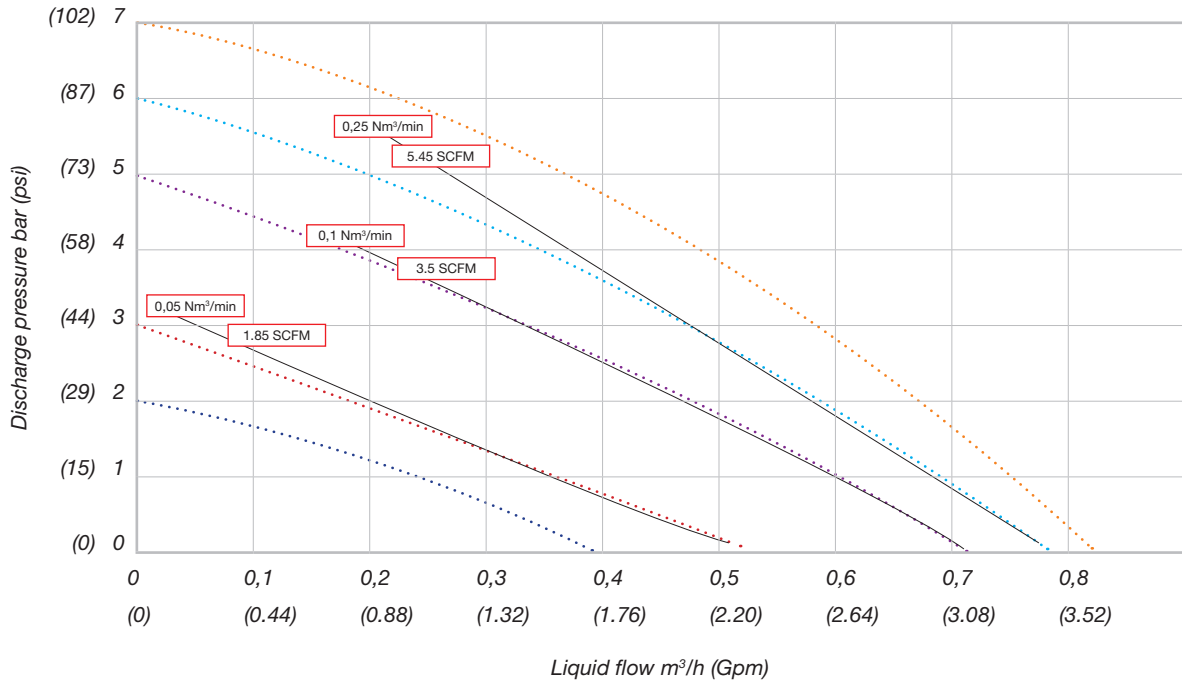

**VA-C20**

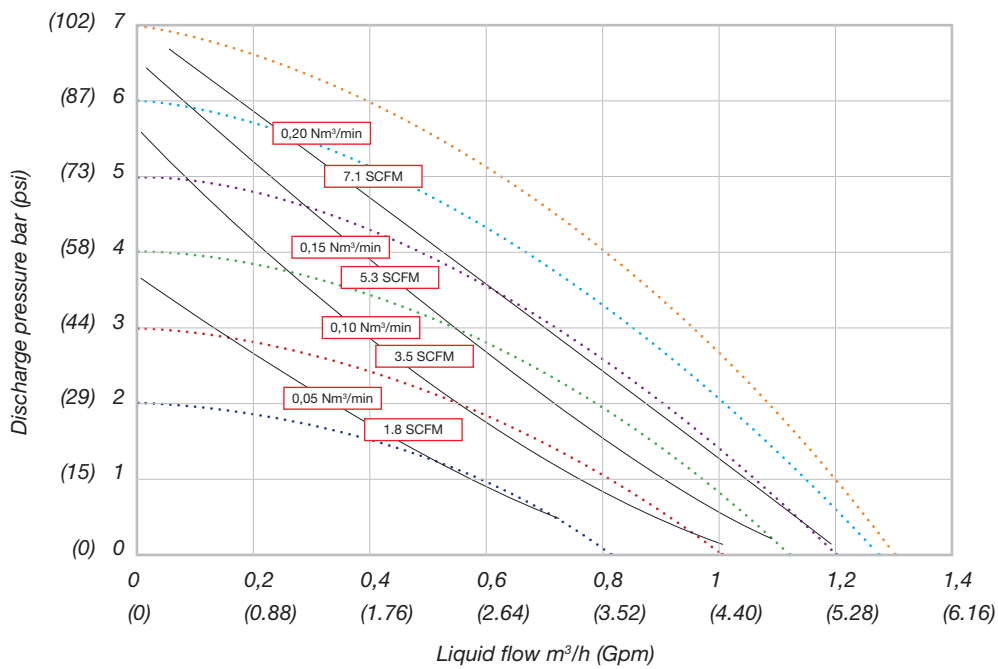

**VA-C50**

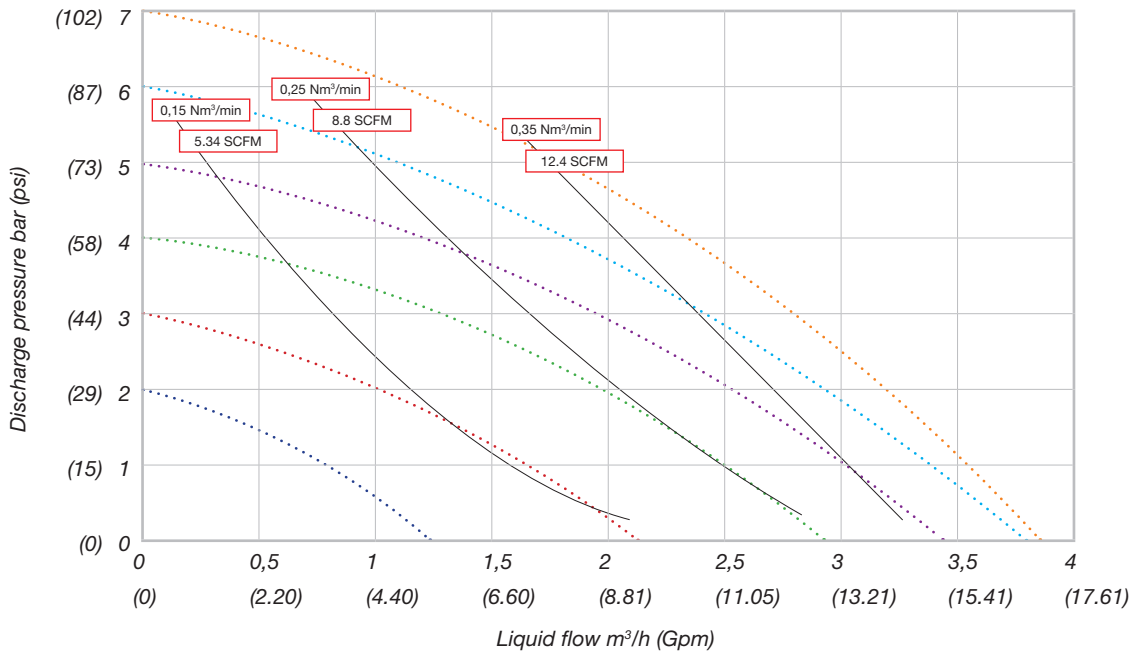

**VA-C130**

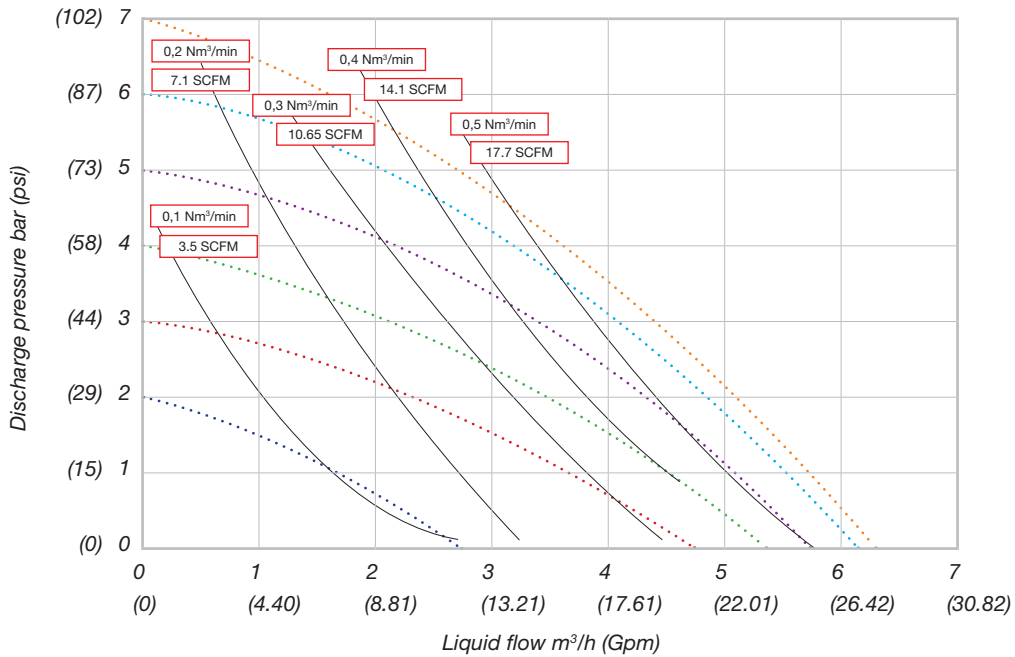



**TECHNICAL DATA**

ISO measurements						
Device model		VA-C10	VA-C20	VA-C50	VA-C130	
Nominal port size	NPT	3/8"	1/2"	3/4"	1 1/4"	
Air connection		R 1/4"	R 1/4"	R 1/4"	R 1/4"	
Weight	kg	1	2	5	10	
Suction lift dry max	mWC					
with cylinder valves		0,7	2	3,5	4,5	
with ball valves		-	0,5	2	2,5	
with spring loaded valves		2,5	3,5			
Suction lift wet max	mWC	8	8	9	9	
		No suction lift wet for ball valves				
Max particle size - suggested	mm	2	3	4	6	
Max particle size - possible	mm	2	4	7	9	
Max operating pressure	bar	7	7	7	7	

US measurements						
Device model		VA-C10	VA-C20	VA-C50	VA-C130	
Nominal port size	NPT	3/8"	1/2"	3/4"	1 1/4"	
Air connection		R 1/4"	R 1/4"	R 1/4"	R 1/4"	
Weight	lbs	2,2	4,4	11	22	
Suction lift dry max	fwc					
with cylinder valves		2,3	6,56	11,48	13,78	
with ball valves		-	1,64	6,56	8,2	
Suction lift wet max	fwc	26,25	26,25	29,53	29,53	
		No suction lift wet for ball valves				
Max particle size - suggested	inch	0,08	0,12	0,16	0,24	
Max particle size - possible	inch	0,08	0,16	0,28	0,35	
Max operating pressure	psi	102	102	102	102	
Max operating temperature	F	158	158	158	158	

## **CUSTOMER SERVICES & GUARANTEE**

### **Customer services**

If you require spare parts, please contact your local distributor, providing the following details:

- Pump Model
- Type
- Serial Number
- Date of First Order

### **Customer services**

All Verder pumps are warranted to the original user against defects in workmanship or materials under normal use (rental use excluded) for two years after purchase date. This warranty does not cover failure of parts or components due to normal wear, damage or failure which in the judgement of Verder arises from misuse.

Parts determined by Verder to be defective in material or workmanship will be repaired or replaced.

### **Limitation of liability**

To the extent allowable under applicable law, Verder's liability for consequential damages is expressly disclaimed. Verder's liability in all events is limited and shall not exceed the purchase price.

### **Warranty disclaimer**

Verder has made an effort to illustrate and describe the products accurately; however, such illustrations and descriptions are for the sole purpose of identification and do not express or imply a warranty that the products are merchantable, or fit for a particular purpose, or that the products will necessarily conform to the illustration or descriptions.

### **Product suitability**

Many regions, states and localities have codes and regulations governing the sale, construction, illustration and/or use of products for certain purposes, which may vary from those in neighbouring areas. While Verder attempts to assure that its products comply with such codes, it cannot guarantee compliance, and cannot be responsible for how the product is installed or used. Before purchasing and using a product, please review the product application as well as the national and local codes and regulations, and be sure that the product, installation, and use complies with them.

End of product life dispose of / reprocess in accordance with local regulations or return to a specialized disposal facility.

In accordance to Machinery Directive 2006/42/WE