

- All Stainless Steel Construction
- Seals 20mm to 110mm Diameter Caps
- High Efficiency
- Optimised Sealing Performance
- Mobile from Line to Line
- High Production Rates
- Also Available with 3kW Output Power

The MICS-2 is a powerful self contained induction cap sealing machine designed to fit into most line arrangements without modification. Its in-built castors allow the machine to be moved easily from line to line, secured in place by use of the adjustable feet and plugged in to the nearest 200v-240v single phase mains electricity supply. The 2kW solid state induction generator is housed in an IP55 rated lockable enclosure with a remote start/stop console for external control. Facilities are provided as standard for interlocking the sealing power of the unit to the conveyor. A flashing beacon on the top of the unit indicates that sealing power has been shut down or latched off.

The versatile 500mm long induction coil provided as standard is designed to seal containers in the range of 20mm through to 110 mm of varying design without change. The coil mounting is fully adjustable allowing for the levelling of the head to the conveyor in both planes and the 'skewing' of the coil to maximise exposure where necessary for larger containers. Relco also manufacture custom built sealing heads and 'tunnel coils' for particular applications and unusual closure designs.

A full range of optional extras are available with the MICS-2 including missing foil detectors, back-up queue and container jam detectors, cocked cap detectors, container ejectors, under/over voltage protection and uprated cooling systems for high temperature locations.

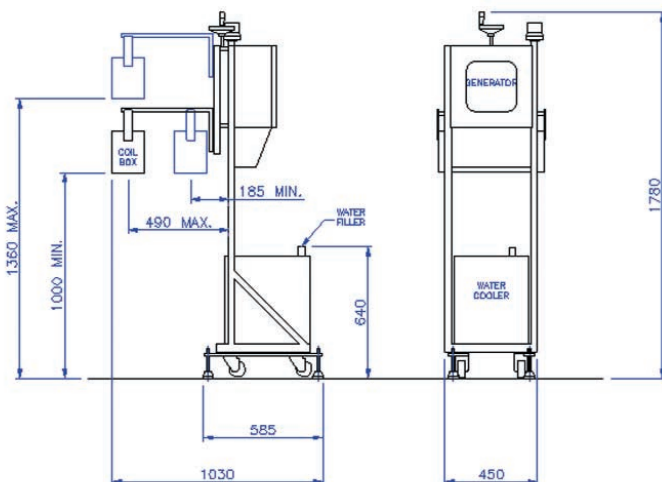

Specifications:

- Supplies:** 200-240v 12Amp Single Phase Electricity (50Hz)
- Dimensions:** 450mm x 585mm x 1780mm with 525mm long induction coil box
- Output Power:** 2kW (3kW Option also available upon request) – Fully Variable
- Weight:** 95Kg
- Construction:** All stainless steel frame with stainless steel IP55 control cabinet and nylon induction coil housing